

System Overview

The Telesis® TMP1700/420 PINSTAMP® marking system permanently prints messages into a variety of materials such as steel, aluminum, and plastic. A hardened pin is pneumatically accelerated to indent dot matrix characters into the item being marked. The shape, size, density, and location of characters are determined by the user through the system software. The marking head moves the pin cartridge through X- and Y-axis motions to reach the correct position for each dot of the characters to be marked. The system software automatically controls pin extension and retraction to mark the message.

TMP1700 Marking Head includes the mechanical motion components to position the marking pin at precise X/Y positions and the pneumatic components to drive the marking pin from, and return the pin to, the pin cartridge.

The TMP1700 marking head is an X/Y-traversing mechanism. Using two stepper motor drives, it accurately and rapidly positions the pin at coordinate-defined locations in marking window within .001" (.025 mm). The TMP1700 accommodates the rigorous dynamics of impacting, rebounding, and rapid positioning of the marking pin through a system of rigid rails and ball bearing saddles, timing belts, and direct-drive, toothed pulleys.

The floating pin design permits high quality, consistent marks on irregular, slightly curved surfaces. It also accommodates applications where marking surfaces cannot be positioned at a consistent distance from the marker.

The internal mechanism is protected from debris by an integral shield. Three stainless steel panels slide against one another, constrained by the cartridge and the high-impact ABS cover, to prevent debris from entering the marking head. A flexible, oil-resistant fabric boot is also available for applications requiring additional protection, especially against liquid sprays and mists.

Marker Cable, pre-wired to the marking head, connects the marker to the controller. The highly flexible cable is 4m (13 ft.) long. Optional extension cables are available for greater distances.

Pin Cartridges, machined from plastic materials, offer long life with little maintenance. Clasps are used to attach the pin cartridge to the marking head for easy cleaning and pin replacement.

Marking Pins for the TMP1700 include the 25L-, 25XL-, 150S-, and 150SA-series, and the 10MP MICRO-PIN™. Refer to the marking head installation drawing for pin stroke (pin extension) dimensions. Refer to the marking depth tables for pin cone angles and depths.

Filter/Regulator Unit includes two regulators with pressure gauges to control the drive air and return air. The regulator first contains a filter to help remove contaminants from the supply air. Two air lines connect the regulated air to the marking head. Drive air fires the impact pin; return air pushes it back into the cartridge. The standard air lines are 12 ft. (3.6 m) long made of 1/4" tubing.

TMC420 Controller includes an integrated keyboard with a four line LCD display. It provides the electrical interface and software control of the TMP1700 marking head. (Refer to *TMC420 Controller Specifications* for details.)

System Options

- Tool Post Assembly
- Oil-resistant, Fabric Boot (debris protection for marking head)
- Marking Head Extension Cables
- TMC420 Controller NEMA 12 Enclosure
- TMC420 Controller Mounting Bracket Kit
- Bar Code Scanner or Bar Code Wand with Cable
- Foot Switch (Start Print) or Pushbutton Station (Start/Abort)
- Backup Utility Software
- Upgrade Utility Software
- Logo/Font Generator Software

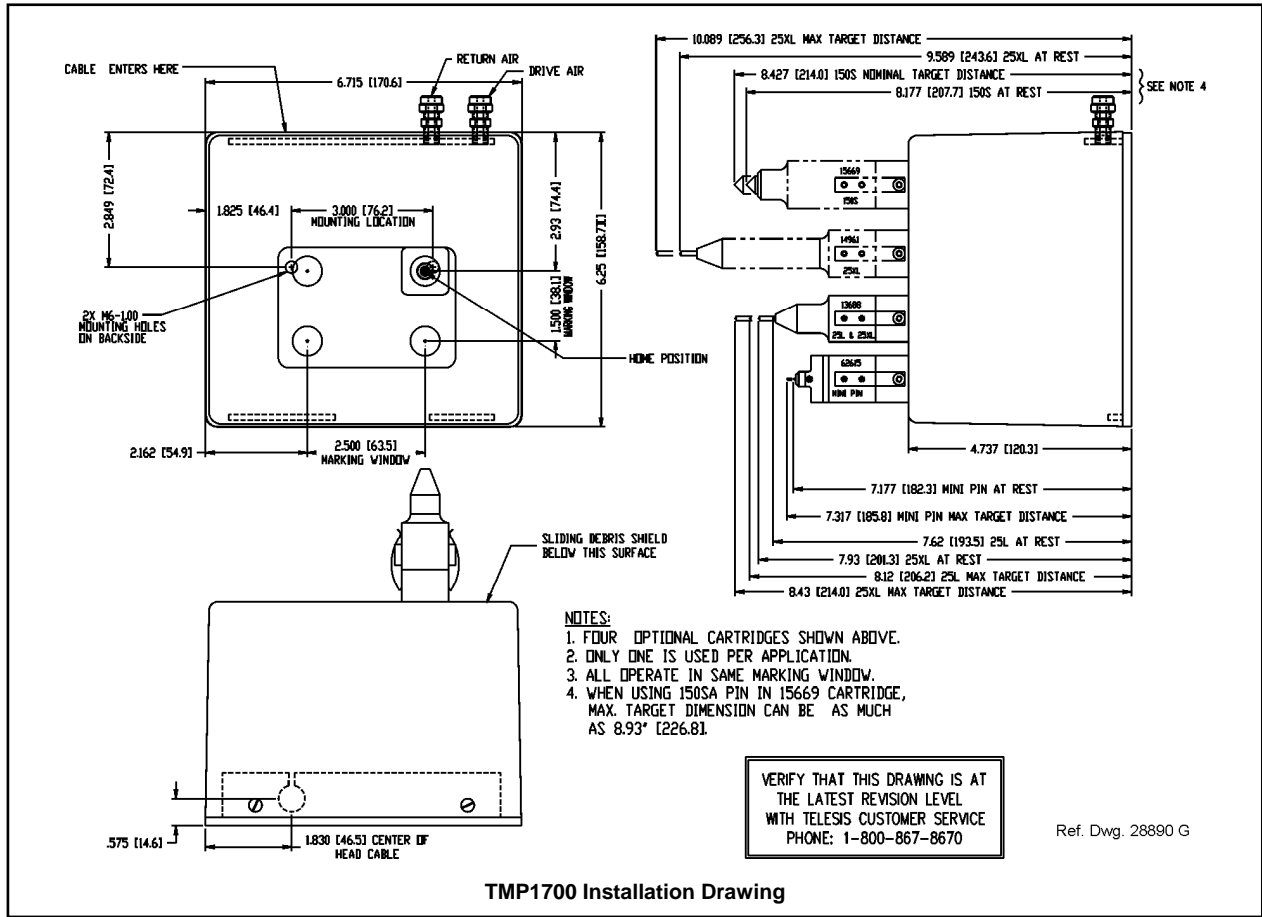

System Setup

When designing a fixture, allow for 3-axis adjustment to aid in horizontal, vertical, and lateral alignment of the marking head.

1. Mount marking head to optional tool post assembly (or other suitable fixture) using two M6 bolts. **Mounting bolts must not extend into marking head more than more 5/8" (15 mm).**
2. Mount filter/regulator assembly, using brackets provided, within 12 ft. (3.6m) of marking head.
3. Connect drive air and return air lines to the connectors on back of marking head.
4. Connect supply air to input port on filter/regulator assembly.
5. Adjust pin stroke, drive air, and return air for proper pin impact depth.
 - Nominal drive air pressure 80 psi (5.5 bars)
 - Nominal return air pressure 20 psi (1.4 bars)

Note: The TMC420 is not a sealed unit. Protect it from potentially damaging conditions and contaminants. Do not block case vents. Ensure the marking system is electrically isolated from any devices that may generate extreme electromagnetic interference (EMI).

6. Locate controller as close as practical to marking head. Standard marker cable length is 4m (13 ft.).
7. Ensure controller power switch (on back panel) is OFF; connect power cable to controller.
8. Connect marker cable from marking head to controller; tighten securely.
9. Position controller power switch to ON (on back panel) to start the system software.

TMP1700 Marking Head

Specifications. The TMP1700 marking head specifications are subject to change without prior notice.

- DIMENSIONS** *refer to TMP1700 Installation Drawing*
- WEIGHT** 6.4 lb. (2.9 kg)
- OPERATING TEMP.** 32° to 122° F (0° to 50° C), non-condensing
- AIR SUPPLY** Clean and dry, 60 to 120 psig (4.2 to 8.3 bars)
- AIR CONSUMPTION** .04 SCFM (idle) 0.6 SCFM (marking)
- MARKING AREA** 2.5 x 1.5" (63 x 38 mm)
- PIN TYPES** 10MP-, 25L-, 25XL-, 150S, or 150SA-series
- PIN MATERIAL** Carbide (10MP-series MICRO-PIN™)
Powdered metal or stainless steel with diamond tip or carbide (25L-, 25XL-series)
Powdered metal or tool steel with carbide tip (150S-, 150SA-series)

Marking Characteristics. The TMP1700 can produce characters as small as .030" (.76mm), printed at any angle within the marking window. Printing resolutions range from 10 dots per inch to 200 dots per inch for an engraved look. The depth of mark can be adjusted over a significant range by adjusting the pin stroke and, to a lesser extent, by adjusting the drive air pressure.

Marking Speeds. Generally, the system will mark four characters per second (using 5x7 font, .125" [3 mm] high characters). Speeds will vary slightly depending on the selected character size, style, and dot density. Specific times can be verified by a Telesis representative.

Pin Life. Pin life depends largely on the type of material being marked, how hard or abrasive it is, and the required marking depth. On typical metals with a hardness of Rockwell Rb47, marking at a depth of .005" (.127 mm), powdered steel pins average about 3 million impressions before needing sharpened; carbide pins average approximately 9 million impressions. If carbide pins are used, marking times will increase by approximately 25% due to the increased weight of the pins.

Marking Depth. The following tables provide sample marking depths. Drive air was set at 80 psi (5.5 bars); return air was set at 20 psi (1.4 bars); pin stroke was set to the maximum allowable distance for each pin type to achieve the maximum depth of mark.

Marking Depths – Type 25L & 25XL Powdered-Metal Pins

MATERIAL (HARDNESS)	22° CONE	30° CONE	45° CONE	60° CONE
Aluminum (Rb3)	.005 in. .127 mm	.007 in. .178 mm	.011 in. .279 mm	.016 in. .406 mm
Brass (Rb18)	.003 in. .076 mm	.005 in. .127 mm	.009 in. .229 mm	.012 in. .305 mm
Cold Rolled Steel (Rc18)	.003 in. .076 mm	.005 in. .127 mm	.008 in. .203 mm	.012 in. .305 mm

Marking Depths – Type 25L & 25XL Carbide Pins

MATERIAL (HARDNESS)	22° CONE	30° CONE	45° CONE	60° CONE
Aluminum (Rb3)	.006 in. .152 mm	.007 in. .178 mm	.010 in. .254 mm	.011 in. .279 mm
Brass (Rb18)	.005 in. .127 mm	.007 in. .178 mm	.008 in. .203 mm	.009 in. .229 mm
Cold Rolled Steel (Rc18)	.004 in. .101 mm	.005 in. .127 mm	.007 in. .178 mm	.009 in. .229 mm

Marking Depths – Type 150S Pins

MATERIAL (HARDNESS)	22° CONE	30° CONE	45° CONE	60° CONE
Aluminum (Rb3)	N/A	.008 in. .203 mm	.012 in. .305 mm	.018 in. .457 mm
Brass (Rb18)	N/A	.007 in. .178 mm	.010 in. .254 mm	.017 in. .432 mm
Cold Rolled Steel (Rc18)	N/A	.006 in. .152 mm	.008 in. .203 mm	.013 in. .330 mm

Marking Depths – Type 150SA Pins

MATERIAL (HARDNESS)	22° CONE	30° CONE	45° CONE	60° CONE
Aluminum (Rb3)	N/A	.008 in. .203 mm	.012 in. .305 mm	N/A
Brass (Rb18)	N/A	.007 in. .178 mm	.010 in. .254 mm	N/A
Cold Rolled Steel (Rc18)	N/A	.006 in. .152 mm	.008 in. .203 mm	N/A

Marking Noise. When marking cold-rolled steel strips at 50% duty cycle, the noise level of the TMP1700 Marking System has been measured at 74.6 dB, using the "time weighted average" approach (average sound exposure over an 8 hour period). It is expected that as the duty cycle rises, the time weighted average will rise also. Typical applications average around 20%-30% duty cycle where the sound pressure level would not exceed 70 dB (A).

Noise-level Tests have been carried out under controlled conditions imitating as closely as possible predicted normal operation.

Conditions such as rigidity of the work piece, material, setting of the machine, ambient noise, etc. may vary when in operational use and would alter the actual noise level.

Despite detailed guidance notes provided with each machine, these conditions would be out of the control of Telesis and must remain the responsibility of the end user to conduct their own tests to establish safe working levels of use.

Vibration Data. Vibration tests were performed under controlled conditions imitating, as closely as possible, typical normal operation.

Conditions such as rigidity of the work piece, material, setting of the machine, etc. may vary in actual operational use and would alter the actual vibration level. Despite detailed guidance instructions provided with each machine, such conditions are beyond the control of Telesis and must remain the responsibility of the end user. Accordingly, you should conduct your own tests to establish safe working levels of use.

The vibration tests were conducted using the following parameters:

- DRIVE AIR PRESSURE:** 4.08 bars (60 psi)
- RETURN AIR PRESSURE:** 1.36 bars (20 psi)
- PIN STROKE:** 8 mm (.31 in)
- MARKING BASE:** 20 mm (.79 in) thick steel
- MARKING SURFACES:** 2 mm (.08 in) thick steel plate
4 mm (.16 in) thick aluminum plate
- MARKING MODE:** Dot
- TEXT MARKED:** TELESIS
(11x16 font, 5mm [.20 in] characters)
HHHEEE000888
(5x7 font, 3mm [.12 in] characters)

The following test results reflect the worst-case scenarios under the given test conditions.

Steel Marking Surface			
Pin	VM	T _(EAV)	T _(ELV)
25C	0.4 m/s ²	more than 24 hr	more than 24 hr
150SA	0.8 m/s ²	more than 24 hr	more than 24 hr
Aluminum Marking Surface			
Pin	VM	T _(EAV)	T _(ELV)
25C	0.6 m/s ²	more than 24 hr	more than 24 hr
150SA	1.2 m/s ²	more than 24 hr	more than 24 hr

where:

- VM** = hand/arm vibration magnitude.
- T_(EAV)** = time to reach the *Exposure Action Value* based on continuous marking.
- T_(ELV)** = time to reach the *Exposure Limit Value* based on continuous marking.

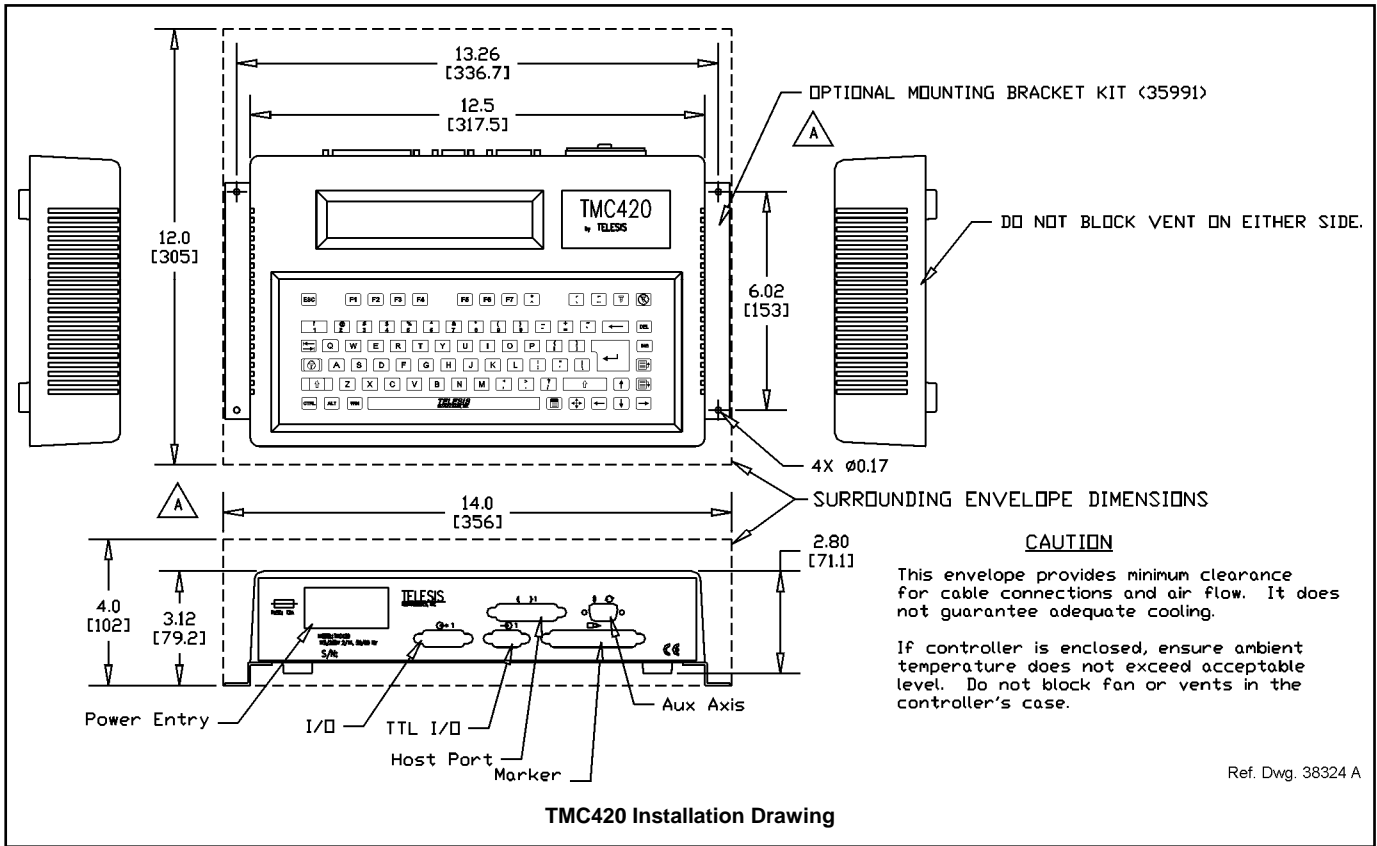

TMC420 Installation Drawing

TMC420 Controller

Configurations. Three models of the TMC420 are available for use with the TMP1700: the TMC420 table-top controller, the TMC420P panel-mounted controller, and the TMC420N enclosure-mounted controller. All controllers provide the same software features and the same connectivity for external communications. Differences occur only in their mounting configurations.

TMC420 Specifications. The TMC420 controller specifications are subject to change without prior notice.

- DIMENSIONS** refer to TMC420 Installation Drawing
- RATING** NEMA 1 (I.P. 30)
- WEIGHT** 2.15 kg (4.75 lb.)
- OPERATING TEMP.** 0° to 50°C (32° to 122° F), non-condensing
- POWER** 95-130 VAC, 2 amps, 50-60 Hz single phase
200-250 VAC, 1 amp, 50-60 Hz single phase
- I/O VOLTAGE** 12 to 24 VDC (customer-supplied)

TMC420P Specifications. The TMC420P controller specifications are subject to change without prior notice.

- DIMENSIONS** refer to TMC420P Installation Drawing
- RATING** NEMA 1 (I.P. 30) stand-alone
NEMA 12 (I.P. 65) appropriately installed
- WEIGHT** 3.10 kg (6.8 lb.)
- OPERATING TEMP.** 0° to 50°C (32° to 122° F), non-condensing
- POWER** 95-130 VAC, 2 amps, 50-60 Hz single phase
200-250 VAC, 1 amp, 50-60 Hz single phase
- I/O VOLTAGE** 12 to 24 VDC (customer-supplied)

TMC420N Specifications. The TMC420N controller specifications are subject to change without prior notice.

- DIMENSIONS** refer to TMC420N Installation Drawing
- RATING** NEMA 12 (I.P. 65)
- WEIGHT** 12.77 kg (28.1 lb.)
- OPERATING TEMP.** 0° to 50°C (32° to 122° F), non-condensing
- POWER** 95-130 VAC, 2 amps, 50-60 Hz single phase
200-250 VAC, 1 amp, 50-60 Hz single phase
- I/O VOLTAGE** 12 to 24 VDC (customer-supplied)

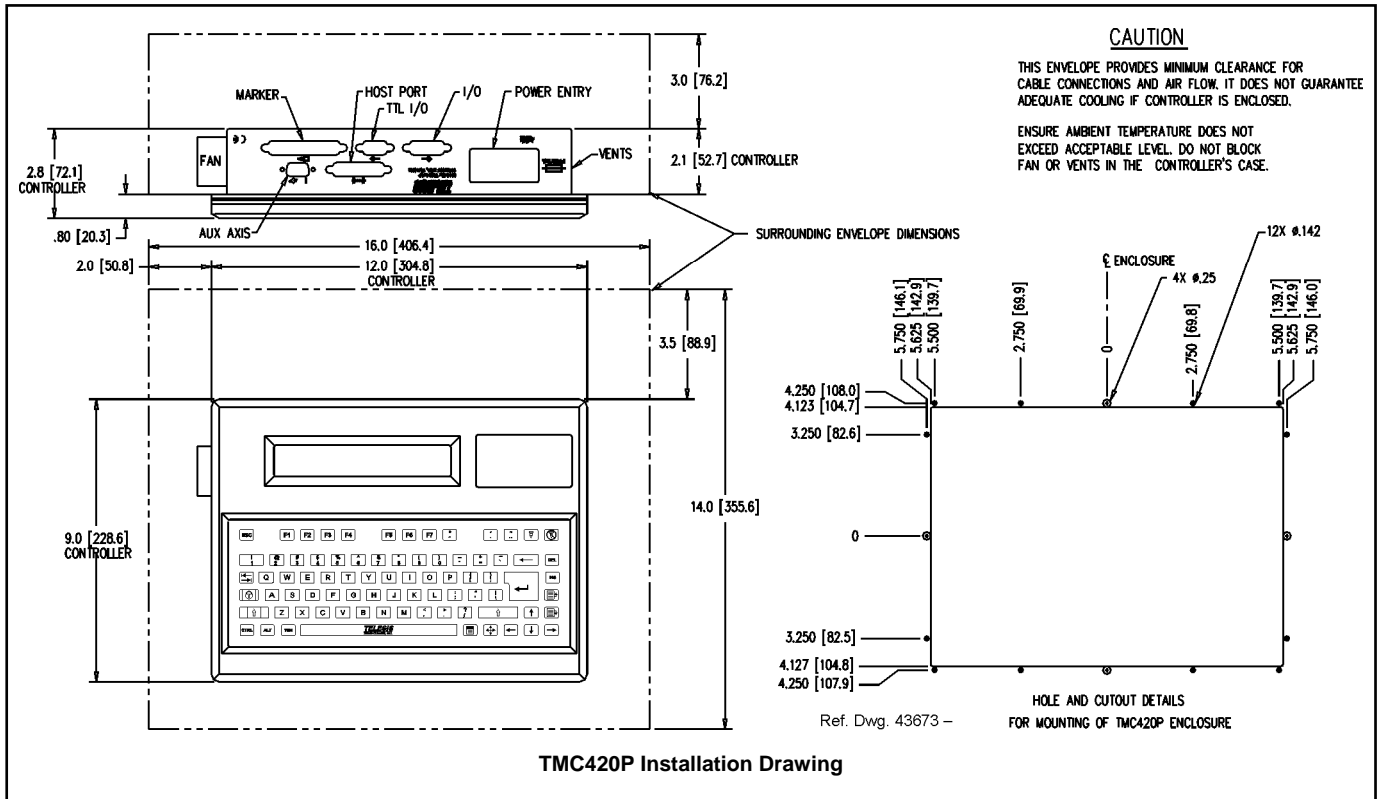

Environmental Considerations. The following environmental considerations must be taken into account when installing the TMC420 controller.

Contaminants. The vented and fan-cooled TMC420 is rated NEMA 1 (IP30). Accordingly, in environments where solid and/or liquid contaminants are present, the possibility exists that these contaminants can be drawn into the TMC420 controller and possibly result in failure of a number of electronic components. For that reason, in these types of environments, the controller must be located in a sealed industrial enclosure. To facilitate such installations, Telesis offers the panel-mounted TMC420P and the enclosure-mounted NEMA 12 (IP65) rated TMC420N. Telesis also offers an optional NEMA 12 (IP65) enclosure in which the TMC420 can be mounted for applications that do not require frequent operator access to the TMC420 display and keyboard.

EMI Susceptibility. Although the system has been found to be in compliance with pertinent susceptibility standards, care should be taken when installing near welders and other extreme generators of electromagnetic interference (EMI). Particular care should be taken to ensure welder currents are not injected through the marking head chassis. The marking head chassis is connected to the electrical service earth ground through the marking head cable. The marking head should be electrically isolated from all surfaces which could become part of a welder current path.

System Software. The system software is permanently installed in the controller. It provides the user interface for the operator to control the marker. The software also provides a library for storing, loading, and editing user-defined patterns. Patterns are files stored in the controller's memory. The controller can store up to 75 patterns. Each pattern contains one or more fields. A field defines a single object and how it will be printed. Fields may define text strings, 2D data matrix symbols, Go-to commands, or Pause commands. Text fields may include alphanumeric characters, symbols, and special message flags. The message flags automatically insert data into the text string, such as serial numbers, times, and dates.

Interface Panel. The interface panel provides various ports for connecting the marker, host computers, logic controllers, or optional accessories.

Serial Interface. The Host Port is used for RS-232 and RS-485 communications with serial devices such as a host computer or bar code scanner. Up to 31 controllers may be used in a multi-drop configuration using the RS-485 interface. The host computer can load patterns, download messages, place the marker on/offline, and monitor system errors. (See *Serial Communications* for details.)

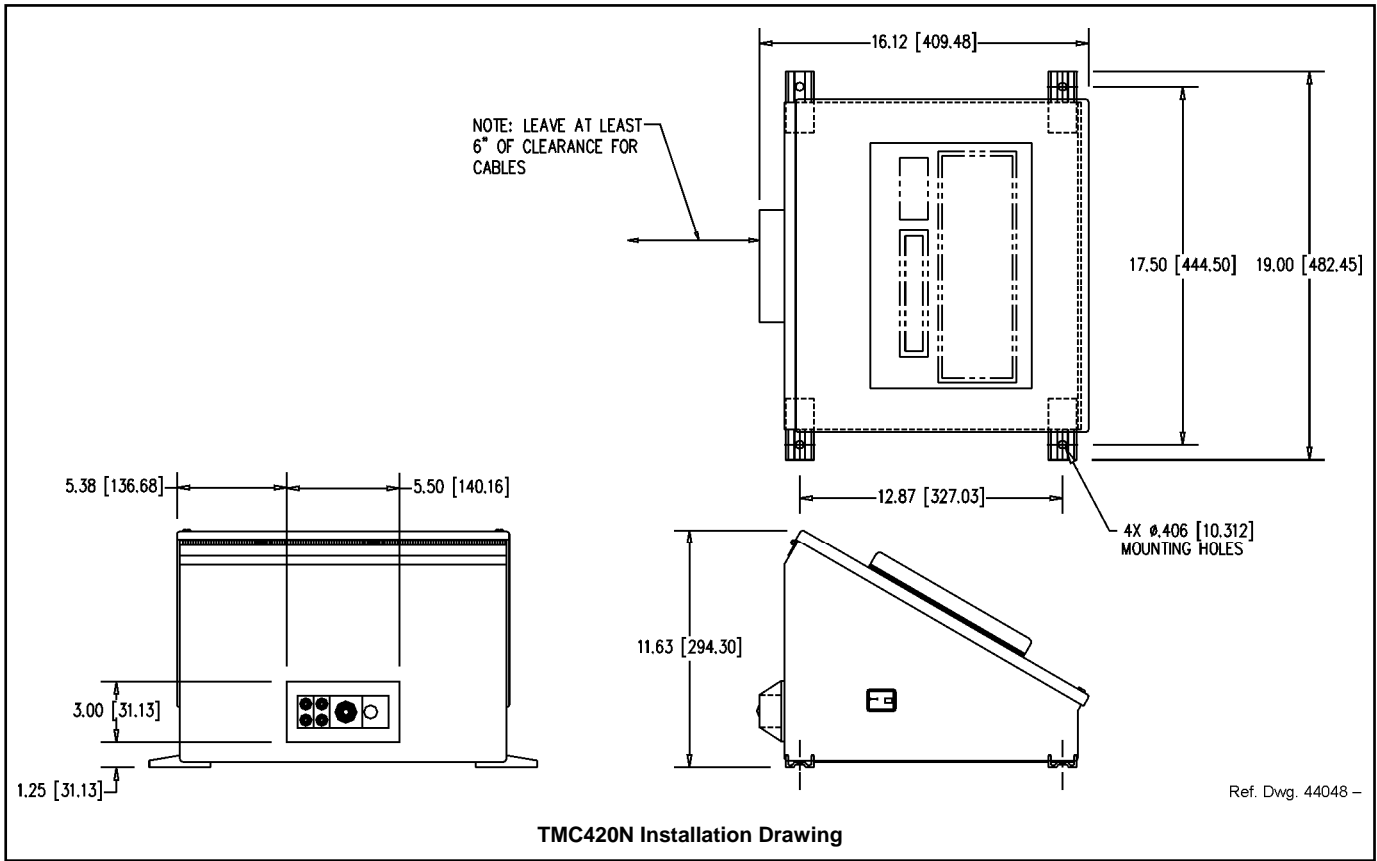

TMC420N Installation Drawing

I/O Control Signals. The TMC420 is configured for DC I/O only. The TTL I/O Port may be used to connect a remote pushbutton control for Start Print and Abort commands. The I/O Port may be used to connect a PLC or other DC I/O source. The I/O Port allows remote control of pattern selection, printing, aborting, placing the marker online, and monitoring of the Ready and Done output signals. Cable connectors and connector pins are supplied with the controller for constructing appropriate interface cables.

- START PRINT** Input signal, begins print cycle
- SEL_0, 1, 2, 3 *** Input signals, remote pattern selection (15* max.)
- SEL_3 *** Input signal, marker online
- ABORT** Input signal, aborts print cycle
- INPUT COMM** For all inputs (+ or – supply)
- READY** Output signal, ready for message or start print
- DONE** Output signal, print cycle complete
- OUTPUT COMM** For all outputs (+ or – supply)

* System software allows SEL_3 signal to be configured for remotely selecting patterns or for remotely placing the marker online. If used for marker online, pattern selection is reduced to 7 patterns (max).

Serial Communications. The Host Port may be used for either RS-232 or RS-485 communication. The RS-232 interface is most often used with remote devices such as bar code readers or host computers. The RS-485 interface is normally used for long transmission distances or multi-drop networks of up to 31 TMC420 controllers. The serial port may be configured to communicate using either the Telesis Programmable Protocol or Telesis Extended Protocol. The following describes the serial data character format on all transmissions to and from the TMC420 controller.

- Asynchronous
- 1200, 2400, 4800, 9600, or 19200 baud-host
- One Start Bit
- One or Two Stop Bit(s)
- Seven or Eight Data Bits
- None, Even or Odd Parity

Programmable Protocol is used where very simple one-way communications are required (such as with bar code scanners). Programmable Protocol provides no error checking or acknowledgment of the transmitted data. Note that XON/XOFF Protocol applies even when Programmable Protocol is selected.

Starting Character specifies where the software begins to count character positions. This number must be entered in ASCII decimal format such as 2 for STX.

Terminating Character identifies the end of transmitted string (usually ASCII carriage return character, decimal 13).

Character Position counted from the starting character ignoring all characters preceding it.

Character Length accepts variable length messages (if set to 0) or messages of a pre-specified, fixed number of characters.

Ignore Character identifies the character to ignore when sent from the host (usually ASCII line feed character, decimal 10)

Message Type allows message-type recognition which defines how the marking system will use data it receives from the host.

- P** loads a specific pattern identified by data extracted from host
- V** updates first variable text field with data extracted from host
- 1** overwrites first text field with data extracted from the host
- Q** updates text in first query buffer with data extracted from host
- 0** indicates that host will provide message type, field number (if applicable), and data; delegates message type selection to the host on message-by-message basis. The host message must use the format **Tnn<string>** where:
 - T** = P, V, 1, or Q to indicate the message type.
 - nn** = two-digit number to indicate field number or query text buffer where data will be placed. Note that a number is not used with Message Type P.
 - <string>** = pattern name (Message Type P) or field data (Message Types V, 1, or Q), as applicable.

Extended Protocol includes error checking and transmission acknowledgment. It should be used in applications where serial communication is a vital part of the marking operation. Extended Protocol must be used in multi-drop applications. All communications are carried out in a master-slave relationship with the host being the master. Only the master has the ability to initiate communications. If the host does not receive a response within three seconds, it should re-transmit its original message. If no response is received after three tries, it should declare the link to be down.

The following describes the message format as sent from the master to the TMC420 controller.

SOH TYPE [##] STX [DATA TEXT] ETX BCC CR

SOH ASCII Start of Header character (001H). The controller ignores all characters received prior to the SOH.

TYPE A single, printable ASCII character that defines the meaning (type) and content of the message downloaded from the host, where:

- 1** overwrites the specified field of currently loaded pattern, using the format **1nn<string>** where nn is the field number.
- V** updates specified variable text field of currently loaded pattern, using the format **Vnn<string>** where nn is the field number.
- Q** updates specified query buffer with the data received from host, using the format **Qnn<string>** where nn is the buffer number.
- P** specifies pattern name to be loaded for printing
- O** resets marker and places it online
- G** initiates a print cycle to mark the currently loaded pattern
- I** requests the marker output status; returns a single-digit hexadecimal value to report state of READY and DONE:

Returned Value	DONE	READY
0	off	Off
1	off	ON
2	ON	Off
3	ON	ON

- S** requests the marker error status; returns a value that represents a particular type of error:

Returned Value	TYPE OF ERROR
0x0000	(no error)
0x0001	ONLINE_ERROR
0x0002	PATTERN_LOAD_ERROR
0x0004	DISALLOWED_NO_PATTERN
0x0008	DISALLOWED_OFFLINE
0x0010	PATTERN_FIELD_ERROR
0x0020	MARKER_ABORTED_ERROR
0x0080	PIX_OUT_OF_RANGE_ERROR
0x0100	RAM_ERROR
0x0200	SN_RANGE_ERROR

[##] Two optional ASCII decimal digits that specify the Station ID number for use in multi-drop network applications. The ID may range from 00-31. Note that "00" is reserved for applications where only one controller is used. In such applications, this field may be eliminated and "00" will be assumed.

STX ASCII Start of Text Character (002H).

[DATA TEXT] Optional field that may be required for certain message types.

ETX ASCII end of text character (003H).

BCC Optional Block Check Code that is generated and sent to improve link reliability by providing fault detection. The BCC is calculated by taking an eight bit addition of the TYPE and DATA TEXT characters and transmitting them as a three digit ASCII decimal number in the range from 000 to 255. If the sum is greater than 255, the most significant bit overflows and is discarded.

CR ASCII Carriage Return Character (00DH).

TRADEMARKS

Telesis and **PINSTAMP** are registered trademarks of Telesis Technologies, Inc. in the United States and/or other countries.

MICRO-PIN is a trademark of Telesis Technologies, Inc. in the United States and/or other countries.