

System Overview

The Telesis® SC3500/420 TeleScribe® Marking System permanently inscribes messages into a variety of materials such as steel, aluminum, and plastic. Marking is accomplished by a hardened pin that is pneumatically pressed into the surface being marked. The shape, size, and location of the inscribed characters are determined by the user through the system software. As the marking head moves the pin cartridge through the X/Y axes, the tip of the extended pin displaces the material being marked, thereby forming continuous-line characters. The system software automatically controls pin extension and retraction to mark the message.

SC3500 Marking Head. Includes the mechanical motion components to position the marking pin at precise X/Y positions and the pneumatic components to extend the pin from, and return the pin to the pin cartridge.

The marking head is an X and Y traversing mechanism. Using two stepper motor drives, it accurately and rapidly positions the pin at coordinate-defined locations in the marking window within .025mm (.001"). The SC3500 accommodates the rigorous and rapid positioning of the marking pin through a system of rigid rails and ball bearing saddles, timing belts, and direct-drive, toothed pulleys.

The floating pin design permits high quality, consistent marks on irregular, slightly curved surfaces. It also accommodates applications where marking surfaces cannot be positioned at a consistent distance from the marker.

Marker Cable. Connects the marking head to the controller. The head cable is a highly flexible cable. The standard cable length is 4 m (13 ft.). Optional cable extensions are available for greater distances.

Marking Pins. Marking pins are available in various cone angles and radius tips. An optional, diamond-tip pin is also available. Refer to the marking head dimension drawing (on next page) for maximum pin extension (pin stroke).

Pin Cartridge. Lightweight pin cartridges are provided for the marking pins. The machined cartridge, piloted to resist shear loads, offers long life with little maintenance. The cartridge is attached to the marking head with four bolts to allow for easy removal, cleaning, and pin replacement.

Filter/Regulator Unit. Includes two regulators with pressure gauges to control the drive air and return air. The first regulator contains a filter to help remove contaminants from the supply air. Two air lines connect the regulated air to the marking head. Drive air extends and holds the impact pin while scribing; return air pushes it back into the cartridge. The standard drive/return air lines are 4 m (13 ft.) long made of 6 mm tubing.

TMC420 Controller. An integrated keyboard/controller with a four line LCD display. It provides the electrical interface and software control of the marking head. (Refer to *TMC420 Controller Specifications* for details.)

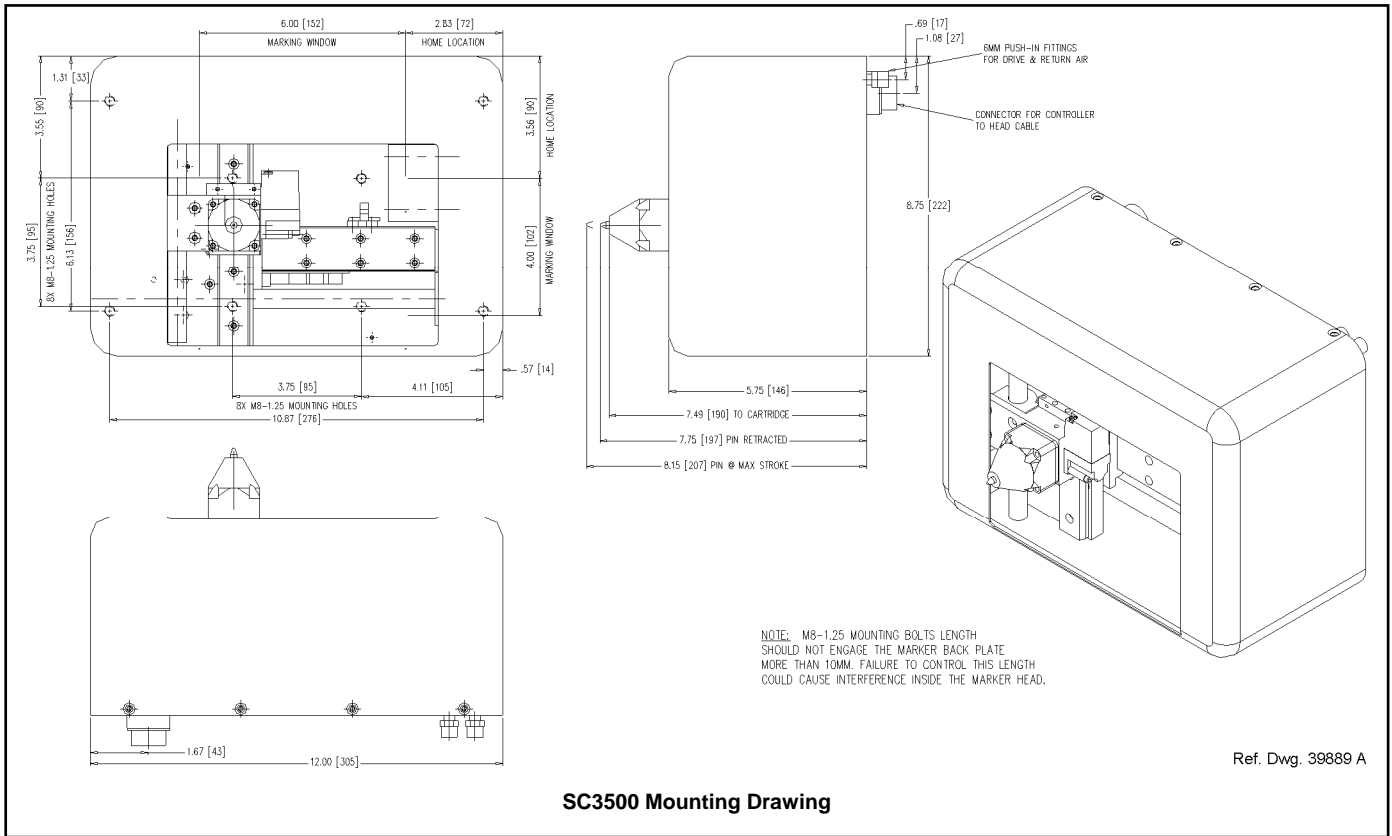

System Setup

The drawn sheet metal cover allows for fixture-mounting. When designing your fixture, allow for 3-axis adjustment to aid in horizontal, vertical, and lateral alignment of marking head.

1. Mount the marking head to a suitable, rigid structure. Refer to the mounting drawing for dimensions and hole locations.

Caution: Mounting bolts must not extend into the marking head more than 10 mm (3/8").

2. Mount the filter-regulator assembly using brackets provided within 4 m (13 ft.) of the marking head.
3. Connect the Drive Air line and Return Air line to the Drive and Return fittings on the back of the marking head.
4. Connect the main air supply to the input port on the filter-regulator assembly.
5. Adjust pin stroke, drive air, and return air for proper depth of mark and for contrast with surface to be marked.
 - Nominal Drive Air pressure 5.5 bars (80 psi)
 - Nominal Return Air pressure 1.4 bars (20 psi)

Note: The TMC420 is not a sealed unit. Protect it from potentially damaging conditions and contaminants. Do not block case vents. Ensure the marking system is electrically isolated from any devices that may generate extreme electromagnetic interference (EMI).

6. Locate controller as close as practical to the marking head. The standard head cable length is 4 m (13 ft).
7. Ensure controller power switch (on back panel) is OFF; connect power cable to controller.
8. Connect marker cable to marking head and to controller.
9. Position controller power switch to ON (on back panel) to start the system software.

System Options

- Marking Head Extension Cables.
- TMC420 Controller Mounting Bracket Kit
- TMC420 Controller NEMA 12 Enclosure
- Bar Code Scanner or Bar Code Wand with Cable
- Backup Utility Software
- Upgrade Utility Software
- Logo/Font Generator Software

SC3500 Marking Head

Specifications. The SC3500 marking head specifications are subject to change without prior notice.

DIMENSIONS	<i>see illustration, above</i> Note: The overall dimensions of the marking head may be reduced for custom applications.
WEIGHT	10.0 kg (22 lb.)
OPERATING TEMP.	0° to 50° C (32° to 122° F), non-condensing
AIR SUPPLY	Clean and dry, 4.2 to 8.3 bars (60 to 120 psig)
AIR CONSUMPTION	.04 SCFM (idle) 0.6 SCFM (marking)
MARKING SPEED	up to two characters/sec using 3mm (.125") high characters (<i>see Marking Speeds</i> for more information)
MARKING AREA	<i>see illustration, above</i>
PIN MATERIAL	Tungsten Carbide (optional: diamond-tipped)

Marking Characteristics. The SC3500 can produce characters as small as 1.5 mm (.06"), printed at any angle within the 150 x 100 mm (6.0 x 4.0") X/Y marking window. Character strings may be marked at any angle (0° to 359° rotation) in 1° increments. The system can also print arcs and arc text.

Noise. The SC3500 provides virtually silent marking with a maximum noise level approximately 72 DBA.

Marking Speeds. Marking speeds vary widely, depending on character size. For example, 3mm (.125") high characters may be printed at two characters/sec. (max). Smaller characters may be printed faster; larger characters may require longer printing times. Specific marking times can be verified by a Telesis representative.

Pin Life. Pin life depends largely on the type of material being marked, how hard or abrasive it is, and the required marking depth.

Marking Depth. The depth of mark may be adjusted by changing the drive air pressure. Maximum marking depths vary widely, depending on the material being marked, the thickness of the material, the marking pin selection, and the air pressure setting. In cold rolled steel with a thickness of .75 mm (.030") or more, marking depths up to .05 mm (.002") may be achieved. In aluminum with a thickness of 1 mm (.040") or more, marking depths up to .075 mm (.003") may be achieved. In thinner materials, the maximum marking depth may increase significantly. Specific marking depths can be verified by a Telesis representative.

TMC420 Controller

Configurations. Three models of the TMC420 are available for use with the SC3500: the TMC420 table-top controller, the TMC420P panel-mounted controller, and the TMC420N enclosure-mounted controller. All controllers provide the same software features and the same connectivity for external communications. Differences occur only in their mounting configurations.

TMC420 Specifications. The TMC420 controller specifications are subject to change without prior notice.

DIMENSIONS	<i>refer to TMC420 Mounting Drawing</i>
RATING	NEMA 1 (I.P. 30)
WEIGHT	2.15 kg (4.75 lb.)
OPERATING TEMP.	0° to 50°C (32° to 122° F), non-condensing
POWER REQ'MENT	95-130 VAC, 2 amps, 50-60 Hz single phase 200-250 VAC, 1 amp, 50-60 Hz single phase
I/O VOLTAGE	12 to 24 VDC (customer-supplied)

TMC420P Specifications. The TMC420P controller specifications are subject to change without prior notice.

DIMENSIONS	<i>refer to TMC420P Mounting Drawing</i>
RATING	NEMA 1 (I.P. 30) stand-alone NEMA 12 (I.P. 65) installed
WEIGHT	3.10 kg (6.8 lb.)
OPERATING TEMP.	0° to 50°C (32° to 122° F), non-condensing
POWER REQ'MENT	95-130 VAC, 2 amps, 50-60 Hz single phase 200-250 VAC, 1 amp, 50-60 Hz single phase
I/O VOLTAGE	12 to 24 VDC (customer-supplied)

TMC420N Specifications. The TMC420N controller specifications are subject to change without prior notice.

DIMENSIONS	<i>refer to TMC420N Mounting Drawing</i>
RATING	NEMA 12 (I.P. 65)
WEIGHT	12.77 kg (28.1 lb.)
OPERATING TEMP.	0° to 50°C (32° to 122° F), non-condensing
POWER REQ'MENT	95-130 VAC, 2 amps, 50-60 Hz single phase 200-250 VAC, 1 amp, 50-60 Hz single phase
I/O VOLTAGE	12 to 24 VDC (customer-supplied)

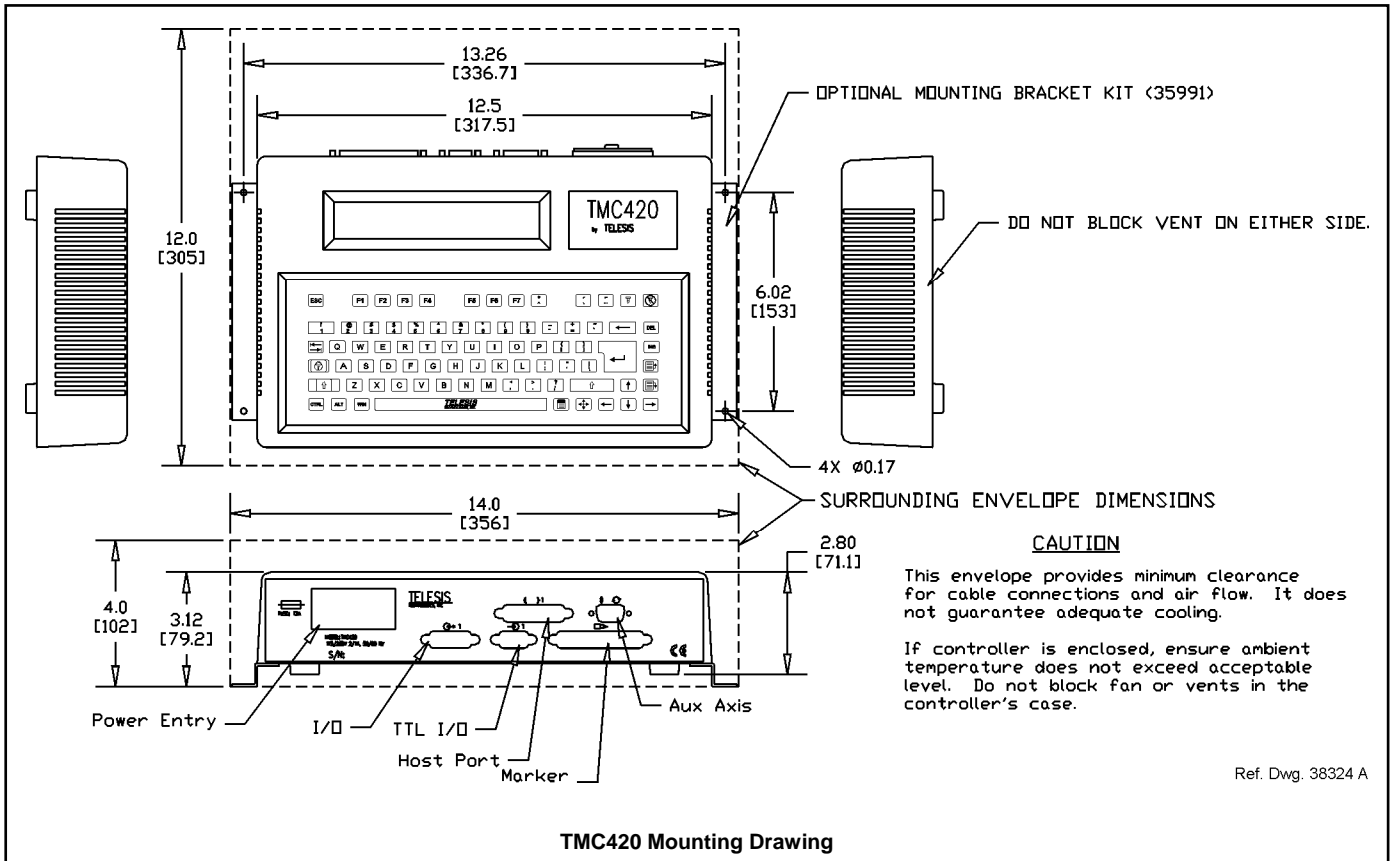

Ref. Dwg. 38324 A

Environmental Considerations. The following environmental considerations must be taken into account when installing the TMC420 controller.

Contaminants. The vented and fan-cooled TMC420 is rated NEMA 1 (IP30). Accordingly, in environments where solid and/or liquid contaminants are present, the possibility exists that these contaminants can be drawn into the TMC420 controller and possibly result in failure of a number of electronic components. For that reason, in these types of environments, the controller must be located in a sealed industrial enclosure. To facilitate such installations, Telesis offers the panel-mounted TMC420P and the enclosure-mounted NEMA 12 (IP65) rated TMC420N. Telesis also offers an optional NEMA 12 (IP65) enclosure in which the TMC420 can be mounted for applications that do not require frequent operator access to the TMC420 display and keyboard.

EMI Susceptibility. Although the system has been found to be in compliance with pertinent susceptibility standards, care should be taken when installing near welders and other extreme generators of electromagnetic interference (EMI). Particular care should be taken to ensure welder currents are not injected through the marking head chassis. The marking head chassis is connected to the electrical service earth ground through the marking head cable. The marking head should be electrically isolated from all surfaces which could become part of a welder current path.

System Software. The system software is permanently installed in the controller. It provides the user interface for the operator to control the marker. The software also provides a library for storing, loading, and editing user-defined patterns. Patterns are files stored in the controller's memory. The controller can store up to 75 patterns. Each pattern contains one or more fields. A field defines a single object and how it will be printed. Fields may define text strings, arcs, arc text strings, Goto or Pause. Text fields may include alphanumeric characters, symbols, and special message flags. The message flags automatically insert data into the text string, such as serial numbers, times, and dates.

Interface Panel. The interface panel provides various ports for connecting the marker, host computers, logic controllers, or optional accessories.

Serial Interface. The Host Port is used for RS-232 and RS-485 communications with serial devices such as a host computer or bar code scanner. Up to 31 controllers may be used in a multi-drop configuration using the RS-485 interface. The host computer can load patterns, download messages, place the marker on/offline, and monitor system errors. (See *Serial Communications* for details.)

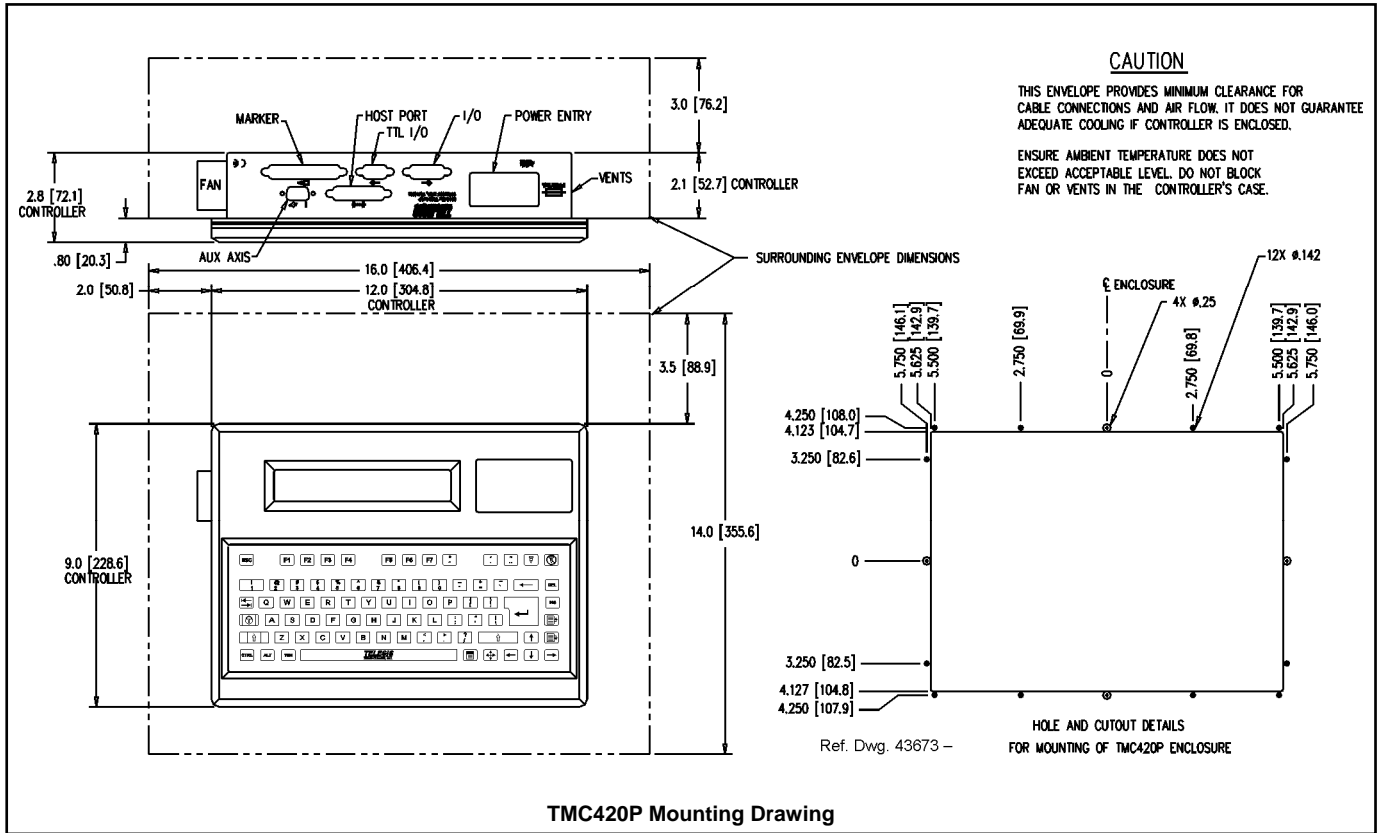

TMC420P Mounting Drawing

I/O Control Signals. The TMC420 is configured for DC I/O only. The TTL I/O Port may be used to connect a remote pushbutton control for Start Print and Abort commands. The I/O Port may be used to connect a PLC or other DC I/O source. The I/O Port allows remote control of pattern selection, printing, aborting, placing the marker online, and monitoring of the Ready and Done output signals. Cable connectors and connector pins are supplied with the controller for constructing appropriate interface cables.

- START PRINT** Input signal, begins print cycle
- SEL_0, 1, 2, 3*** Input signals, remote pattern selection (15* max.)
- SEL_3*** Input signal, marker online
- ABORT** Input signal, aborts print cycle
- INPUT COMM** For all inputs (+ or - supply)
- READY** Output signal, ready for message or start print
- DONE** Output signal, print cycle complete
- OUTPUT COMM** For all outputs (+ or - supply)

* System software allows SEL_3 signal to be configured for remotely selecting patterns or for remotely placing the marker online. If used for marker online, pattern selection is reduced to 7 patterns (max).

Serial Communications. The Host Port may be used for either RS-232 or RS-485 communication. The RS-232 interface is most often used with remote devices such as bar code readers or host computers. The RS-485 interface is normally used for long transmission distances or multi-drop networks of up to 31 TMC420 controllers. The serial port may be configured to communicate using either the Telesis Programmable Protocol or Telesis Extended Protocol. The following describes the serial data character format on all transmissions to and from the TMC420 controller.

- Asynchronous
- 1200, 2400, 4800, 9600, or 19200 baud-host
- One Start Bit
- One or Two Stop Bit(s)
- Seven or Eight Data Bits
- None, Even or Odd Parity

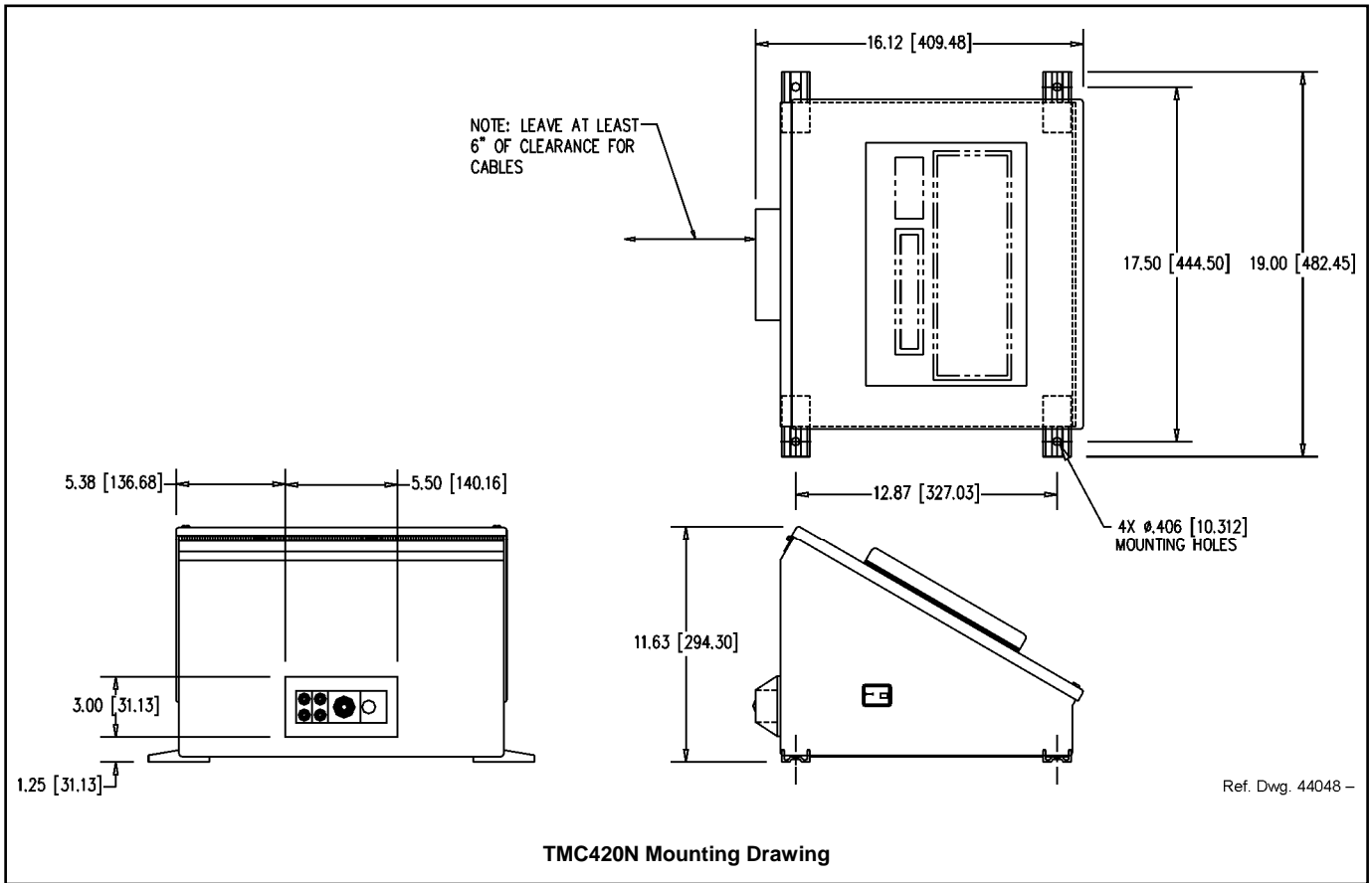

Programmable Protocol is used where very simple one-way communications are required (such as with bar code scanners). Programmable Protocol provides no error checking or acknowledgment of the transmitted data. Note that XON/XOFF Protocol applies even when Programmable Protocol is selected.

Starting Character specifies where the software begins to count character positions. This number must be entered in ASCII decimal format such as 2 for STX.

Terminating Character identifies the end of transmitted string (usually ASCII carriage return character, decimal 13).

Character Position counted from the starting character ignoring all characters preceding it.

Character Length accepts variable length messages (if set to 0) or messages of a pre-specified, fixed number of characters.

Ignore Character identifies the character to ignore when sent from the host (usually ASCII line feed character, decimal 10).

Message Type allows message-type recognition which defines how the marking system will use data it receives from the host.

- P** loads a specific pattern identified by data extracted from host
- V** updates first variable text field with data extracted from host
- 1** overwrites first text field with data extracted from the host
- Q** updates text in first query buffer with data extracted from host
- 0** indicates that host will provide message type, field number (if applicable), and data; delegates message type selection to the host on message-by-message basis. The host message must use the format **Tnn<string>** where:
 - T** = P, V, 1, or Q to indicate the message type.
 - nn** = two-digit number to indicate field number or query text buffer where data will be placed. Note that a number is not used with Message Type P.
 - <string>** = pattern name (Message Type P) or field data (Message Types V, 1, or Q), as applicable.

Extended Protocol includes error checking and transmission acknowledgment. It should be used in applications where serial communication is a vital part of the marking operation. Extended Protocol must be used in multi-drop applications. All communications are carried out in a master-slave relationship with the host being the master. Only the master has the ability to initiate communications. If the host does not receive a response within three seconds, it should re-transmit its original message. If no response is received after three tries, it should declare the link to be down

The following describes the message format as sent from the master to the TMC420 controller.

SOH TYPE [##] STX [DATA TEXT] ETX BCC CR

SOH ASCII Start of Header character (001H). The controller ignores all characters received prior to the SOH.

TYPE A single, printable ASCII character that defines the meaning (type) and content of the message downloaded from the host, where:

- 1** overwrites the specified field of currently loaded pattern, using the format **1nn<string>** where nn is the field number.
- V** updates specified variable text field of currently loaded pattern, using the format **Vnn<string>** where nn is the field number.
- Q** updates specified query buffer with the data received from host, using the format **Qnn<string>** where nn is the buffer number.
- P** specifies pattern name to be loaded for printing
- O** resets marker and places it online
- G** initiates a print cycle to mark the currently loaded pattern
- I** requests the marker output status; returns a single-digit hexadecimal value to report state of READY and DONE:

Returned Value	DONE	READY
0	off	Off
1	off	ON
2	ON	Off
3	ON	ON

- S** requests the marker error status; returns a value that represents a particular type of error:

Returned Value	TYPE OF ERROR
0x0000	(no error)
0x0001	ONLINE_ERROR
0x0002	PATTERN_LOAD_ERROR
0x0004	DISALLOWED_NO_PATTERN
0x0008	DISALLOWED_OFFLINE
0x0010	PATTERN_FIELD_ERROR
0x0020	MARKER_ABORTED_ERROR
0x0080	PIX_OUT_OF_RANGE_ERROR
0x0100	RAM_ERROR
0x0200	SN_RANGE_ERROR

[##] Two optional ASCII decimal digits that specify the Station ID number for use in multi-drop network applications. The ID may range from 00-31. Note that “00” is reserved for applications where only one controller is used. In such applications, this field may be eliminated and “00” will be assumed.

STX ASCII Start of Text Character (002H).

[DATA TEXT] Optional field that may be required for certain message types.

ETX ASCII end of text character (003H).

BCC Optional Block Check Code that is generated and sent to improve link reliability by providing fault detection. The BCC is calculated by taking an eight bit addition of the TYPE and DATA TEXT characters and transmitting them as a three digit ASCII decimal number in the range from 000 to 255. If the sum is greater than 255, the most significant bit overflows and is discarded.

CR ASCII Carriage Return Character (00DH).

TRADEMARKS

Telesis and **TeleScribe** are registered trademarks of Telesis Technologies, Inc. in the United States and/or other countries.