

System Overview

The Telesis® TMP4210/420 PINSTAMP® is a high-speed, single-pin marking system that permanently prints messages into a variety of materials such as steel, aluminum, and plastic. A hardened pin is pneumatically accelerated to indent dot matrix characters into the item being marked. The shape, size, density, and location of characters are determined by the user through the system software. The marking head moves the pin cartridge through X- and Y-axis motions to reach the correct position for each dot of the characters to be marked. The system software automatically controls pneumatic pin extension and retraction to mark the message.

The **TMP4210 Marking Head** includes the mechanical motion components to position the marking pin at precise X/Y positions and the pneumatic components to drive the marking pin from, and return the pin to, the pin cartridge.

The TMP4210 marking head is an X/Y-traversing mechanism. Using two stepper motor drives, it accurately positions the pin cartridge at coordinate-defined locations in marking window within .008mm (in Fine mode) and .032mm (in Standard mode). The TMP4210 uses a rack-and-pinion drive system to rapidly position the pin cartridge and to accommodate the rigorous dynamics of impacting and rebounding.

The floating pin design permits consistent, high-quality marks, even on irregular, slightly curved surfaces. It also accommodates applications where marking surfaces cannot be positioned at a consistent distance from the marker.

TMP4210 Configurations include a hand-held version and a fixture-mounted version. The hand-held marker is available for portable operation. It incorporates a pistol grip handle with a push button trigger switch and an integral standoff to position the marker against the marking surface. The hand-held marker can be optionally

fitted with a v-block standoff and/or a hanger attachment. The v-block standoff provides additional stability when marking on round or curved surfaces. The hanger allows the marker to be easily suspended from a cable balancer. The fixture-mounted unit is available for mounting in a stationary location.

Pin Cartridges. The standard system uses non-lubricated, lightweight pin cartridges. The cartridge may be mounted with the pin oriented toward the left side of the mark or reversed with the pin oriented closer to the marker centerline. This optional offset configuration shifts the marking window 25 mm (1.0 in) to the left along the X-axis. The variable configuration allows for more flexibility in your marking applications.

Marking Pins. The TMP4210 uses 25S-series and 150SA-series marking pins available in various cone (tip) angles. Refer to the marking head installation drawing for pin stroke (pin extension) dimensions.

The **Marker Cable** connects the marking head to the controller. The highly flexible cable is 4m (13.1 ft.) long and attaches to the back of the marker with a quick disconnect connector. Optional extension cables lengths are available.

The **Filter/Regulator Unit** includes two regulators with pressure gauges to control drive air and return air. The first regulator contains a filter to help remove contaminants from the supply air. Two air lines connect the regulated air to the marking head. Drive air fires the impact pin; return air pushes it back into the cartridge. Standard air lines are 4m (13.1 ft.) long made of 6mm tubing.

TMC420 Controller provides the electrical interface and software control of the TMP4210 marking head. (Refer to *TMC420 Controller Specifications* for details.)

TMP4210/420 Marking System

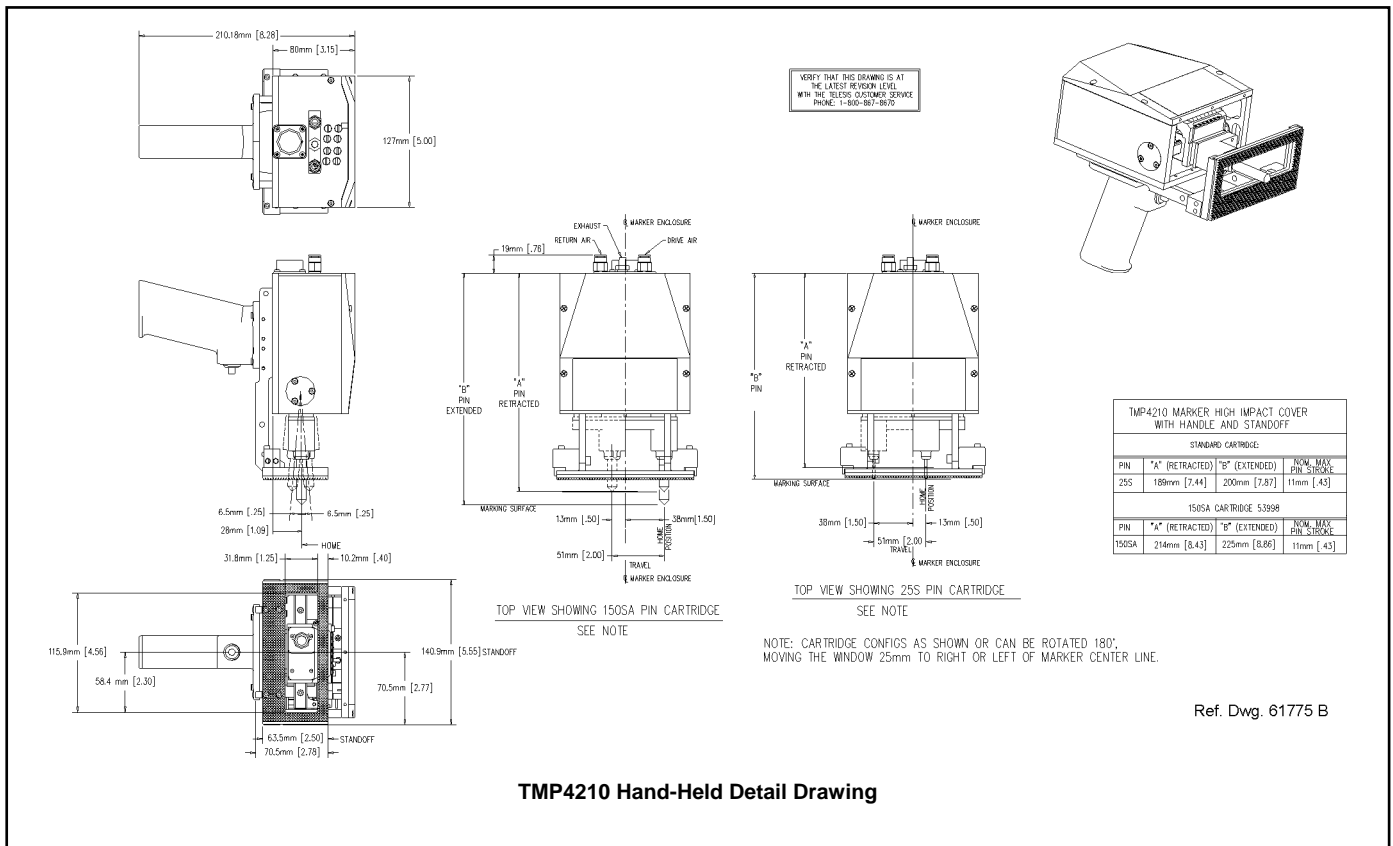

TMP4210 Hand-Held Detail Drawing

System Setup

- Fixture-mounted markers only.** When designing a fixture, allow for 3-axis adjustment to aid in horizontal, vertical, and lateral alignment of the marking head. Mount marking head to a suitable fixture using four M5-0.80 bolts. **Mounting bolts must not extend into marking head more than 10mm (0.375 in.).**
- Mount filter/regulator assembly, using brackets provided, within 4m (13.1 ft.) of marking head.
- Connect drive air and return air lines to the connectors on back of marking head.
- Connect supply air to input port on filter/regulator assembly.
- Adjust drive air and return air for proper pin impact depth.
 - Nominal drive air pressure 5.5 bars (80 psi)
 - Nominal return air pressure 1.5 bars (20 psi)
- Adjust pin stroke for proper pin impact depth.
- Locate controller as close as practical to marking head. Standard marker cable length is 4m (13.1 ft.).
- Ensure controller power switch (on back panel) is OFF; connect power cable to controller.
- Connect marker cable to controller; tighten securely.
- Position controller power switch to ON (on back panel) to start the system software.

Note: The TMC420 is not a sealed unit. Protect it from potentially damaging conditions and contaminants. Do not block case vents. Ensure the marking system is electrically isolated from any devices that may generate extreme electromagnetic interference (EMI).

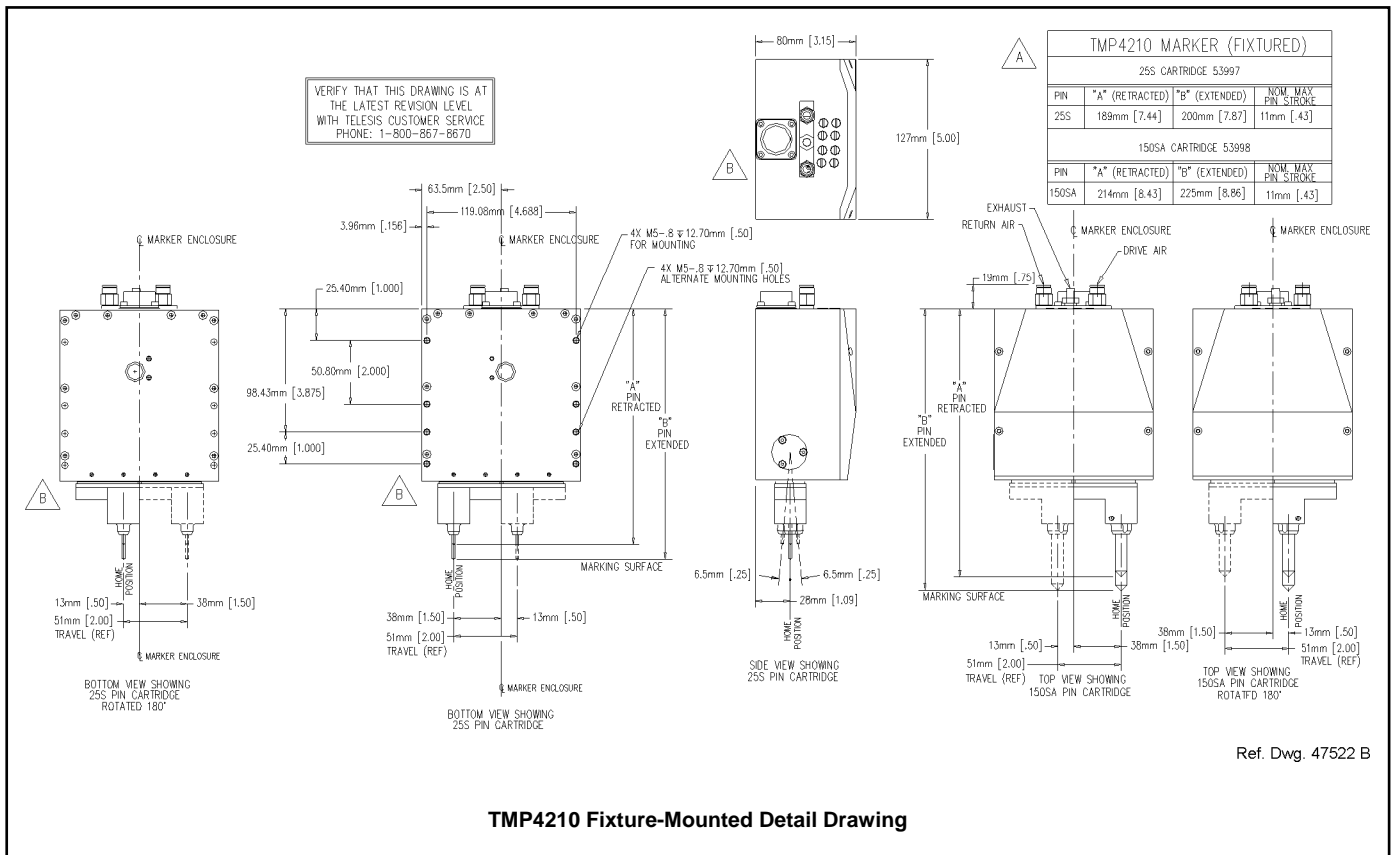

TMP4210 Fixture-Mounted Detail Drawing

System Options

- Standoff V-Block Kit (Hand-held markers only)
- Standoff Hanger Kit (Hand-held markers only)
- Marking Head Extension Cables
- TMC420 Controller Mounting Bracket Kit
- TMC420 Controller NEMA® 12 Enclosure
- Bar Code Scanner
- Bar Code Wand
- Backup Utility Software
- Upgrade Utility Software
- Logo/Font Generator Software

TMP4210 Marking Head

Specifications. The TMP4210 marking head specifications are subject to change without prior notice.

DIMENSIONS	<i>see illustrations</i>
RATING	NEMA® 2 (I.P. 41) with optional, protective debris shield installed
WEIGHT	HAND-HELD: 1.91 kg (4.18 lb) excluding marker cable FIXTURED: 1.63 kg (3.58 lb) excluding marker cable, handle, and standoff
OPERATING TEMP.	0° to 50°C (32° to 122° F), non-condensing
AIR SUPPLY	Clean and dry, 4.2 to 8.3 bars (60 to 120 psi)
AIR CONSUMPTION	0.15 L/sec (0.32 SCFM) idle 0.28 L/sec (0.60 SCFM) marking
MARKING AREA	51 x 13mm (2.0 x .50 in.)
PIN TYPES	25S-series, various cone (tip) angles 150SA-series, various cone (tip) angles
PIN MATERIAL	Powdered Steel or Stainless Steel with Diamond Tip or Carbide (25S-series) Powdered Steel or Tool Steel with Carbide Tip (150SA-series)

TMP4210 Marking Head *(continued)*

Marking Characteristics. The TMP4210 can produce characters as small as 0.75mm (0.03 in.) high. Text strings may be rotated 180° to print inverted. Characters can be printed with resolutions from 4 to 79 dots/cm (10 to 200 dots/in.) for an engraved look. The depth of mark can be adjusted over a significant range by adjusting the pin stroke and, to a lesser extent, by adjusting the drive air pressure.

Marking Speeds. The system can mark 3mm (0.118 in.) high characters in the 5x7 font at a rate of 3.5 characters per second. Speeds will vary widely depending on the selected character size, style, and dot density. Specific times can be verified by a Telesis representative.

Marking Noise. Although every attempt is made to reduce noise, the material being marked significantly influences the noise level. For example, marking a solid lead block produces less noise than marking a thin-walled steel pipe.

Pin Life. Pin life depends largely on the type of material being marked, how hard or abrasive it is, and the required marking depth. On typical metals with a hardness of Rockwell Rb47, marking at a depth of .127mm (0.005 in.), powdered steel pins average about 3 million impressions before needing sharpened; carbide pins average about 9 million impressions.

Vibration Data. Vibration tests were performed under controlled conditions imitating, as closely as possible, typical normal operation.

Conditions such as rigidity of the work piece, material, setting of the machine, etc. may vary in actual operational use and would alter the actual vibration level. Despite detailed guidance instructions provided with each machine, such conditions are beyond the control of Telesis and must remain the responsibility of the end user.

Accordingly, you should conduct your own tests to establish safe working levels of use.

The vibration tests were conducted using the following parameters:

DRIVE AIR PRESSURE:	4.08 bars (60 psi)
RETURN AIR PRESSURE:	1.36 bars (20 psi)
PIN STROKE:	8 mm (.31 in)
MARKING BASE:	20 mm (.79 in) thick steel
MARKING SURFACES:	2 mm (.08 in) thick steel plate 4 mm (.16 in) thick aluminum plate
MARKING MODE:	Dot
TEXT MARKED:	TELESIS (11x16 font, 5mm [.20 in] characters) HHHEEE000888 (5x7 font, 3mm [.12 in] characters)

The following test results reflect the worst-case scenarios under the given test conditions.

Steel Marking Surface			
Pin	VM	T _(EAV)	T _(ELV)
25C	0.4 m/s ²	more than 24 hr	more than 24 hr
150SA	0.8 m/s ²	more than 24 hr	more than 24 hr
Aluminum Marking Surface			
Pin	VM	T _(EAV)	T _(ELV)
25C	0.6 m/s ²	more than 24 hr	more than 24 hr
150SA	1.2 m/s ²	more than 24 hr	more than 24 hr

where:

- VM** = hand/arm vibration magnitude.
- T_(EAV)** = time to reach the *Exposure Action Value* based on continuous marking.
- T_(ELV)** = time to reach the *Exposure Limit Value* based on continuous marking.

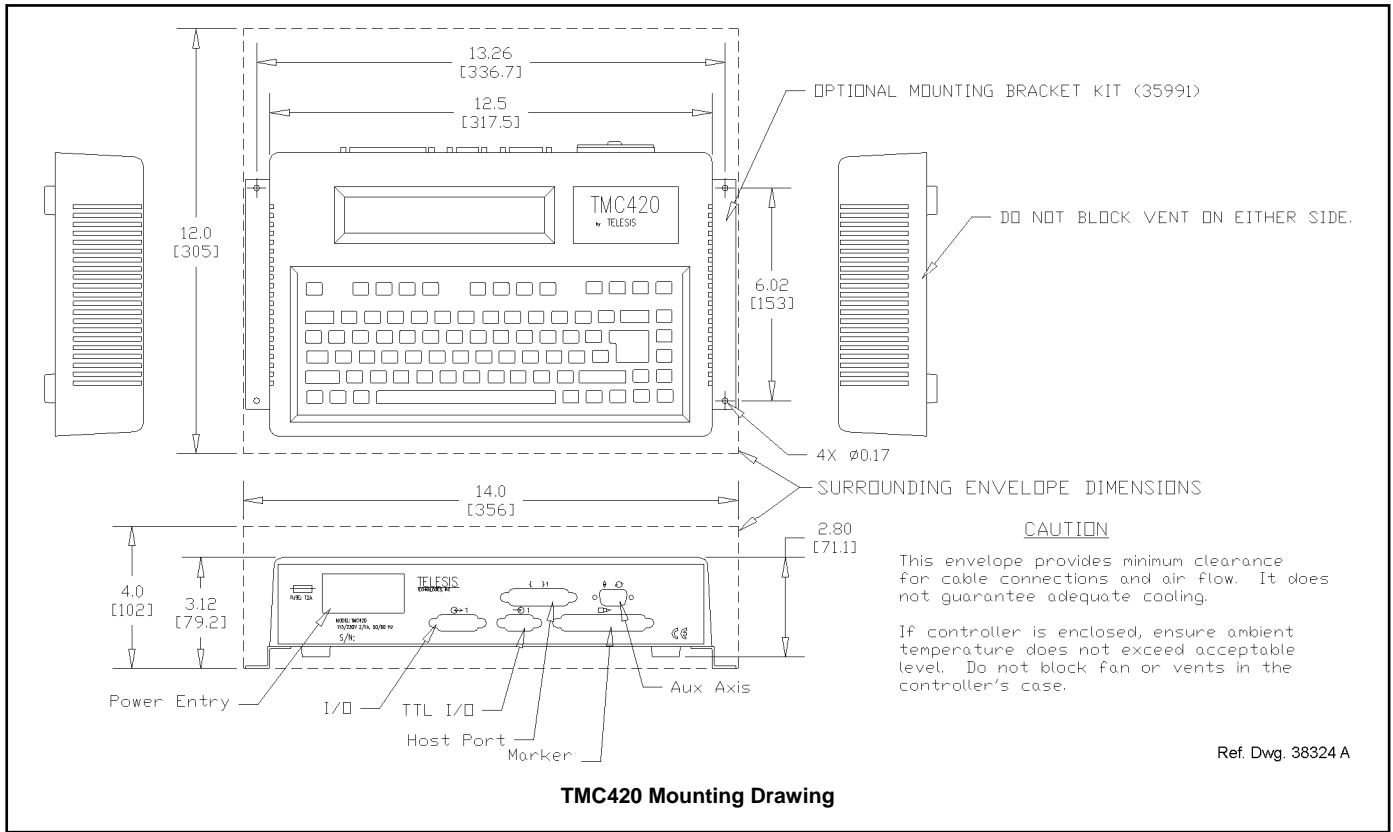

TMC420 Controller

Configurations. Three models of the TMC420 are available for use with the TMP4210: the TMC420 table-top controller, the TMC420P panel-mounted controller, and the TMC420N enclosure-mounted controller. All controllers provide the same software features and the same connectivity for external communications. Differences occur only in their mounting configurations.

TMC420 Specifications. The TMC420 controller specifications are subject to change without prior notice.

DIMENSIONS	<i>refer to TMC420 Mounting Drawing</i>
RATING	NEMA® 1 (I.P. 30)
WEIGHT	2.15 kg (4.75 lb.)
OPERATING TEMP.	0° to 50°C (32° to 122° F), non-condensing
POWER	95-130 VAC, 2 amps, 50-60 Hz single phase 200-250 VAC, 1 amp, 50-60 Hz single phase
I/O VOLTAGE	12 to 24 VDC (customer-supplied)

TMC420P Specifications. The TMC420P controller specifications are subject to change without prior notice.

DIMENSIONS	<i>refer to TMC420P Mounting Drawing</i>
RATING	NEMA® 1 (I.P. 30) stand-alone NEMA® 12 (I.P. 65) installed
WEIGHT	3.10 kg (6.8 lb.)
OPERATING TEMP.	0° to 50°C (32° to 122° F), non-condensing
POWER	95-130 VAC, 2 amps, 50-60 Hz single phase 200-250 VAC, 1 amp, 50-60 Hz single phase
I/O VOLTAGE	12 to 24 VDC (customer-supplied)

TMC420N Specifications. The TMC420N controller specifications are subject to change without prior notice.

DIMENSIONS	<i>refer to TMC420N Mounting Drawing</i>
RATING	NEMA® 12 (I.P. 65)
WEIGHT	12.77 kg (28.1 lb.)
OPERATING TEMP.	0° to 50°C (32° to 122° F), non-condensing
POWER	95-130 VAC, 2 amps, 50-60 Hz single phase 200-250 VAC, 1 amp, 50-60 Hz single phase
I/O VOLTAGE	12 to 24 VDC (customer-supplied)

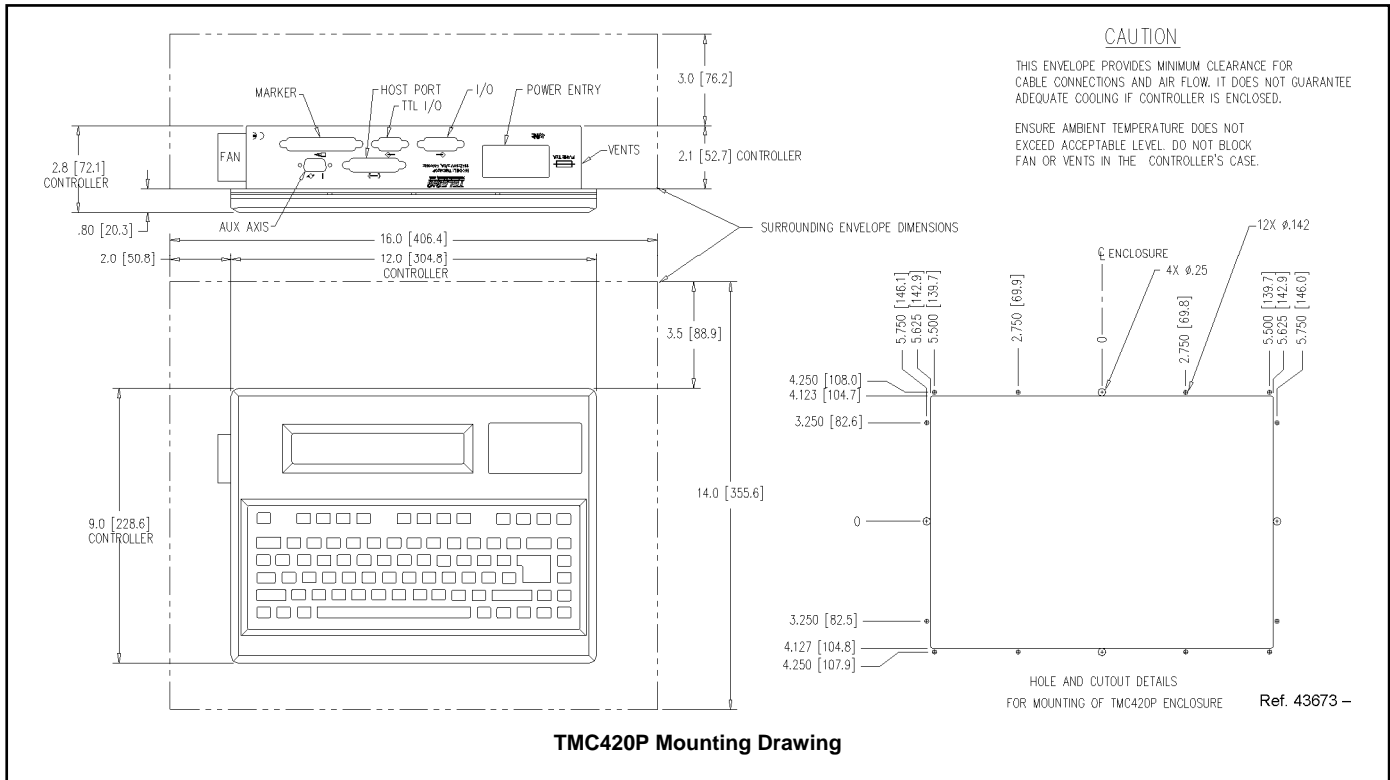

TMC420 Controller (continued)

Environmental Considerations. The following environmental considerations must be taken into account when installing the TMC420 controller.

Contaminants. The vented and fan-cooled TMC420 is rated NEMA[®] 1 (IP30). Accordingly, in environments where solid and/or liquid contaminants are present, the possibility exists that these contaminants can be drawn into the TMC420 controller and possibly result in failure of a number of electronic components. For that reason, in these types of environments, the controller must be located in a sealed industrial enclosure. To facilitate such installations, Telesis offers the panel-mounted TMC420P and the enclosure-mounted NEMA[®] 12 (IP65) rated TMC420N. Telesis also offers an optional NEMA[®] 12 (IP65) enclosure in which the TMC420 can be mounted for applications that do not require frequent operator access to the TMC420 display and keyboard.

EMI Susceptibility. Although the system has been found to be in compliance with pertinent susceptibility standards, care should be taken when installing near welders and other extreme generators of electromagnetic interference (EMI). Particular care should be taken to ensure welder currents are not injected through the marking head chassis. The marking head chassis is connected to the electrical service earth ground through the marking head cable. The marking head should be electrically isolated from all surfaces which could become part of a welder current path.

System Software

System Software. The system software is permanently installed in the controller. It provides the user interface for the operator to control the marker. The software also provides a library for storing, loading, and editing user-defined patterns. Patterns are files stored in the controller's memory. The controller can store up to 75 patterns. Each pattern contains one or more fields. A field defines a single object and how it will be printed. Fields may define text strings, 2D data matrix symbols, Go-To commands, or Pause commands. Text fields may include alphanumeric characters, symbols, and special message flags. The message flags automatically insert data into the text string, such as serial numbers, times, and dates.

Interface Panel. The interface panel provides various ports for connecting the marker, host computers, logic controllers, or optional accessories.

Serial Interface. The Host Port is used for RS-232 and RS-485 communications with serial devices such as a host computer or bar code scanner. Up to 31 controllers may be used in a multi-drop configuration using the RS-485 interface. The host computer can load patterns, download messages, place the marker on/offline, and monitor system errors. (See *Serial Communications* for details.)

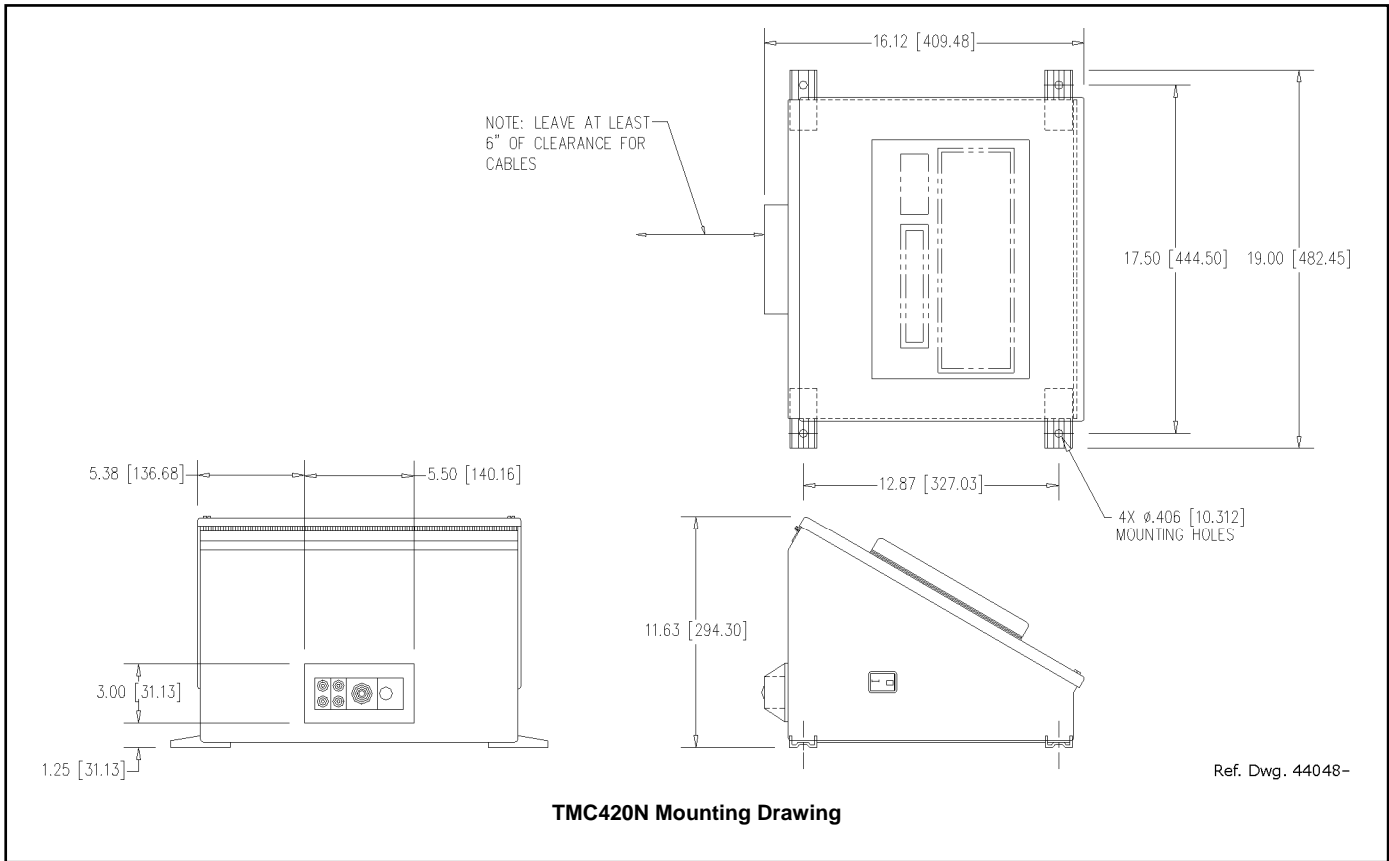

System Software *(continued)*

I/O Control Signals. The TMC420 is configured for DC I/O only. The TTL I/O Port may be used to connect a remote pushbutton control for Start Print and Abort commands. The I/O Port may be used to connect a PLC or other DC I/O source. The I/O Port allows remote control of pattern selection, printing, aborting, placing the marker online, and monitoring of the Ready and Done output signals. Cable connectors and connector pins are supplied with the controller for constructing appropriate interface cables.

- | | |
|-------------------------|--|
| START PRINT | Input signal, begins print cycle |
| SEL_0, 1, 2, 3 * | Input signals, remote pattern selection (15* max.) |
| SEL_3 * | Input signal, marker online |
| ABORT | Input signal, aborts print cycle |
| INPUT COMM | For all inputs (+ or – supply) |
| READY | Output signal, ready for message or start print |
| DONE | Output signal, print cycle complete |
| OUTPUT COMM | For all outputs (+ or – supply) |

* System software allows SEL_3 signal to be configured for remotely selecting patterns or for remotely placing the marker online. If used for marker online, pattern selection is reduced to 7 patterns (max).

Serial Communications. The Host Port may be used for either RS-232 or RS-485 communication. The RS-232 interface is most often used with remote devices such as bar code readers or host computers. The RS-485 interface is normally used for long transmission distances or multi-drop networks of up to 31 TMC420 controllers. The serial port may be configured to communicate using either the Telesis Programmable Protocol or Telesis Extended Protocol. The following describes the serial data character format on all transmissions to and from the TMC420 controller.

- Asynchronous
- 1200, 2400, 4800, 9600, or 19200 baud-host
- One Start Bit
- One or Two Stop Bit(s)
- Seven or Eight Data Bits
- None, Even or Odd Parity

System Software *(continued)*

Programmable Protocol is used where very simple one-way communications are required (such as with bar code scanners). Programmable Protocol provides no error checking or acknowledgment of the transmitted data. Note that XON/XOFF Protocol applies even when Programmable Protocol is selected.

Starting Character specifies where the software begins to count character positions. This number must be entered in ASCII decimal format such as 2 for STX.

Terminating Character identifies the end of transmitted string (usually ASCII carriage return character, decimal 13).

Character Position counted from the starting character ignoring all characters preceding it.

Character Length accepts variable length messages (if set to 0) or messages of a pre-specified, fixed number of characters.

Ignore Character identifies the character to ignore when sent from the host (usually ASCII line feed character, decimal 10)

Message Type allows message-type recognition which defines how the marking system will use data it receives from the host.

- P** loads a specific pattern identified by data extracted from host
- V** updates first variable text field with data extracted from host
- 1** overwrites first text field with data extracted from the host
- Q** updates text in first query buffer with data extracted from host
- 0** indicates that host will provide message type, field number (if applicable), and data; delegates message type selection to the host on message-by-message basis. The host message must use the format **Tnn<string>** where:
 - T** = P, V, 1, or Q to indicate the message type.
 - nn** = two-digit number to indicate field number or query text buffer where data will be placed. Note that a number is not used with Message Type P.
 - <string>** = pattern name (Message Type P) or field data (Message Types V, 1, or Q), as applicable.

Extended Protocol includes error checking and transmission acknowledgment. It should be used in applications where serial communication is a vital part of the marking operation. Extended Protocol must be used in multi-drop applications. All communications are carried out in a master-slave relationship with the host being the master. Only the master has the ability to initiate communications. If the host does not receive a response within three seconds, it should re-transmit its original message. If no response is received after three tries, it should declare the link to be down.

The following describes the message format as sent from the master to the TMC420 controller.

SOH TYPE [##] STX [DATA TEXT] ETX BCC CR

SOH ASCII Start of Header character (001H). The controller ignores all characters received prior to the SOH.

TYPE A single, printable ASCII character that defines the meaning (type) and content of the message downloaded from the host, where:

- 1** overwrites the specified field of currently loaded pattern, using the format **1nn<string>** where nn is the field number.
- V** updates specified variable text field of currently loaded pattern, using the format **Vnn<string>** where nn is the field number.
- Q** updates specified query buffer with the data received from host, using the format **Qnn<string>** where nn is the buffer number.
- P** specifies pattern name to be loaded for printing
- O** resets marker and places it online
- G** initiates a print cycle to mark the currently loaded pattern
- I** requests the marker output status; returns a single-digit hexadecimal value to report state of READY and DONE:

Returned Value	DONE	READY
0	off	Off
1	off	ON
2	ON	Off
3	ON	ON

- S** requests the marker error status; returns a value that represents a particular type of error:

Returned Value	TYPE OF ERROR
0x0000	(no error)
0x0001	ONLINE_ERROR
0x0002	PATTERN_LOAD_ERROR
0x0004	DISALLOWED_NO_PATTERN
0x0008	DISALLOWED_OFFLINE
0x0010	PATTERN_FIELD_ERROR
0x0020	MARKER_ABORTED_ERROR
0x0080	PIX_OUT_OF_RANGE_ERROR
0x0100	RAM_ERROR
0x0200	SN_RANGE_ERROR

[##] Two optional ASCII decimal digits that specify the Station ID number for use in multi-drop network applications. The ID may range from 00-31. Note that "00" is reserved for applications where only one controller is used. In such applications, this field may be eliminated and "00" will be assumed.

STX ASCII Start of Text Character (002H).

[DATA TEXT] Optional field that may be required for certain message types.

ETX ASCII end of text character (003H).

BCC Optional Block Check Code that is generated and sent to improve link reliability by providing fault detection. The BCC is calculated by taking an eight bit addition of the TYPE and DATA TEXT characters and transmitting them as a three digit ASCII decimal number in the range from 000 to 255. If the sum is greater than 255, the most significant bit overflows and is discarded.

CR ASCII Carriage Return Character (00DH).

TRADEMARKS

Telesis and **PINSTAMP** are registered trademarks of Telesis Technologies, Inc. in the United States and/or other countries.

NEMA is the registered trademark and service mark of the National Electrical Manufacturers Association.