

System Overview

The Telesis® CO50 is a 50W, RF-excited, sealed-tube, CO₂ laser marking system that provides a galvo-steered beam designed for marking. The CO50 laser marking system is excellent for marking substrates like wood, glass, Plexiglas®, quartz, ceramics, fabrics, and other organic materials.

The CO50 laser offers these advantages:

- Air-cooling – no external water or refrigerant needed
- Compact laser marking head and simple mounting system
- Detachable 6 ft. (1.8m) umbilical cable for easy integration
- Key switch, Laser Off palm button, interlocked safety shutter, and emission indicators
- DoD-compliant Unique Identification (UID) marking

System Configuration

The CO50 is available in two configurations. One is capable of marking only stationary objects. The other is capable of marking objects while they are moving (i.e., mark-on-the-fly operation). The basic laser system consists of the following components.

Laser Controller – contains circuit boards, electrical components, and the operator console

Umbilical Cable Assembly – includes power and data cables

Laser Marking Head – includes the laser cavity optics, shutter assembly, galvanometer assembly, and flat-field lens. A red aiming diode is included with markers configured for stationary marking (optional for mark-on-the-fly markers).

Remote Shutter Pendant – contains emission indicator, laser stop button, and controls to remotely open/close the shutter

Software – Merlin® II LS Laser Marking Software

System Computer – supplied by Telesis or by customer

The modular design allows for major components to be easily replaced and returned to Telesis if required.

Laser System Options

- Co-axial red aiming diode for pin point marking alignment with markers configured for mark-on-the-fly (standard with markers configured for stationary marking).
- Pushbutton station (start/abort)
- Externally-mounted focus-finder diode
- Mark-on-the-fly kit to interface with customer-supplied encoder for marking objects in linear or circular motion
- Desktop computer or Notebook computer with powered cardbus-to-PCI expansion enclosure
- Programmable X-, Y, or Z-axis (requires two-axis controller)
- Tool post w/ manual hand crank for z-axis adjustment
- Rotary drive fixture (requires two-axis controller)
- I/O Options:
 - TTL via PCI-DIO24 Card (Kit #53920)
 - Opto-isolated via Merlin DCIO Module (Kit #53928)
 - Two-axis Controller (for auxiliary axes; additional I/O)
- Workstation / Work Area Enclosures
- Fume Extraction Vacuum Systems

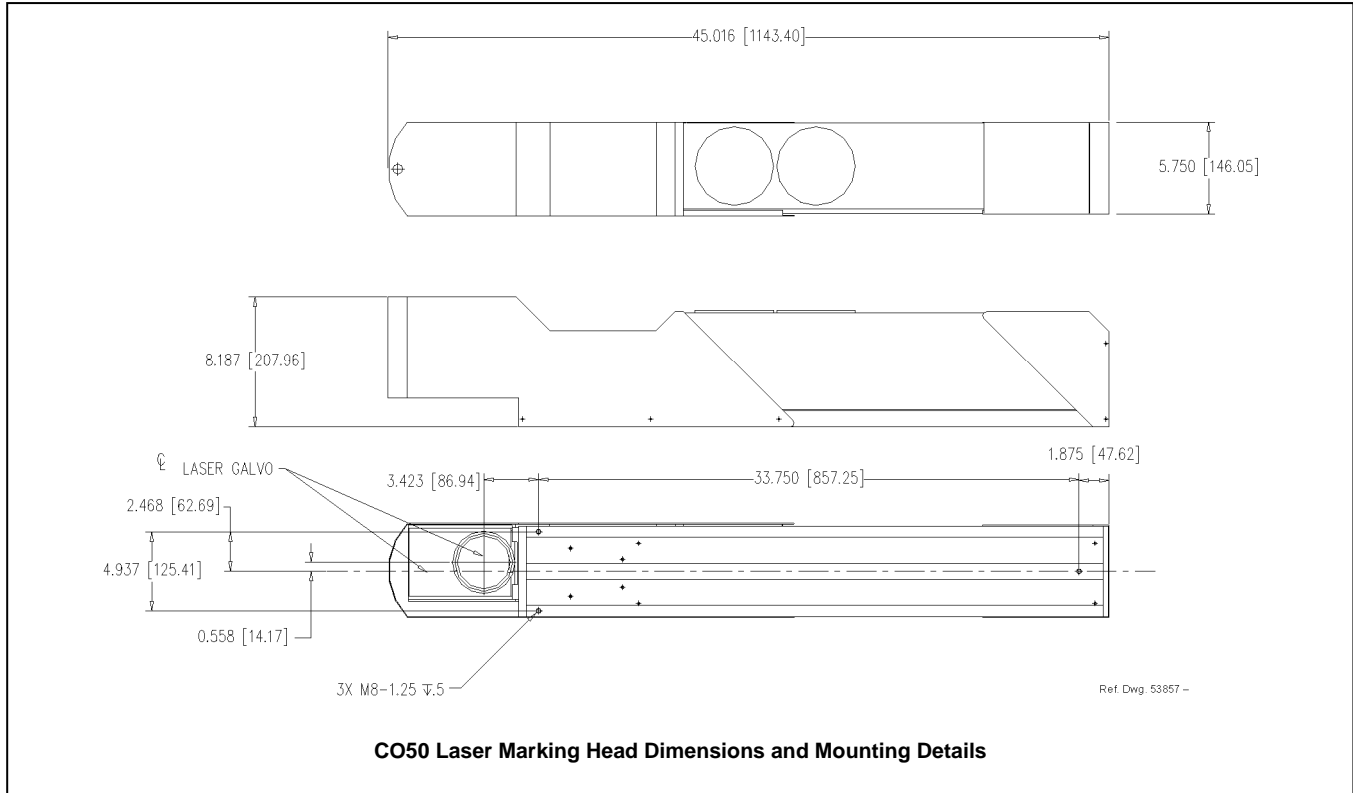

System Setup

Complete installation procedures are provided in the *CO50 Installation/Maintenance Manual*. The following procedures are listed for reference only to provide a general overview of the installation process.

1. Equipment should remain powered down and in the OFF position until the mounting is complete.
2. Place the computer, monitor keyboard and laser controller in the desired location. Locate the controller as close as practical to the laser marking head. The standard umbilical length is 1.8 meters (6 feet).
3. Place the laser marking head onto the mounting position taking care not to bend or kink the umbilical cable. The umbilical cable will take an approximately 200 mm (8 in.) diameter bend without damage.
4. Mount the laser marking head per the following guidelines:
 - A minimum distance of 200 mm (8 in.) should be allowed at the rear of the laser marking head to allow for proper installation of the umbilical.
 - Mount the laser marking head using three M8-1.25 bolts and lock washers. **Torque to 191 in-lb. (21.59 N-m).**
5. Ensure laser controller power switch (on front panel) is OFF.
6. Connect the remaining cables.
7. Refer to the *CO50 Operation Supplement* for proper startup procedure of the complete system.
8. Refer to the laser marking system *Operation Manual* for complete information on using the system software.

System Specifications

Compliance.....	CDRH
Laser Type.....	RF-excited, continuous wave, sealed-tube, carbon dioxide laser
Wavelength.....	10.6 micrometers (µm)
CW Average Power	50 watts
Long Term Output Power Drift..	< ± 5%
Power Consumption	approx. 8.5 amps at 115 VAC
Input Power	115 VAC, single-phase, 15A, 50/60Hz 230 VAC, single-phase, 7.5A, 50/60Hz
Supply Voltage Fluctuation	< ±10% with clean ground line
Operational Temperature	15° to 30°C (59° to 86°F)
Recommended Temperature	16° to 24°C (61° to 75°F)
Ambient Relative Humidity.....	10% to 90% non-condensing

Laser Marking Head

The laser marking head incorporates the latest technology in sealed-tube, RF-excited, carbon dioxide lasers, providing excellent output power, stability, and reliability in a rugged compact modular package.

Laser Marking Head Specifications

Dimensions (L x W x H)	1143.40 x 146.05 x 207.96 mm (45.016 x 5.750 x 8.187 in.)
Surrounding Envelope	1346 x 356 x 406 mm (53.0 x 14.0 x 16.0 in.)
Mounting Weight.....	approx. 25.45 Kg (56 lbs.)
Mounting Holes	three factory-tapped M8-1.25
Positioning.....	visible red aiming diode (optional for mark-on-the-fly systems)
Field Resolution.....	16 bit (65535 data points)
Galvanometer Repeatability	< 22 micro radian
Marking Field Size	lens-dependent, see chart
Laser Umbilical Cable Length....	1.8 m (6 ft.), detachable
Cooling	air cooled, fans/filters

Visible Red Aiming Diode

Laser marking heads configured to mark stationary objects include a visible red diode that can be viewed on the work surface without the need for protective safety goggles. (The aiming diode is optional for systems with mark-on-the-fly capability).

The aiming diode provides a safe and convenient aid for laser setup and part programming. Since the red beam is located *after* the shutter, the aiming beam may be used with the shutter opened or closed. Additionally, the visible red beam may be used with the lasing beam during the marking cycle. Note that protective eyewear **must** *always* be worn when the laser is in operation.

Marking Field Size

The size of the marking field is dependent on lens type. See *Flat-Field Lens*.

Marking Depth. Simple laser parameters can be operator programmed to create depths ranging from simple surface discoloration, shallow laser etching or deep laser engraving. Marking depth is dependent on several factors including; material, lens type selected and other laser parameters. Please contact Telesis for the proper setting for your specific application.

Flat-Field Lens

The flat-field lens is key to the marking performance of the system. This is the final coated optical lens that the beam will pass through before it strikes the marking target. This lens is called a flat field lens because when the beam is focused, the focus lies in a plane perpendicular to the optical axis of the lens.

The following chart outlines the available lenses, the resulting image field provided by the lens, and the working clearance (in millimeters and inches).

Lens	Image Field		Working Clearance	
	(mm)	(in.)	(mm)	(in.)
100 mm	70 x 70	2.76 x 2.76	81	3.19
150 mm	100 x 100	3.94 x 3.94	131	5.16
200 mm	140 x 140	5.51 x 5.51	183	7.20
250 mm	170 x 170	6.69 x 6.69	233	9.17
300 mm	205 x 205	8.07 x 8.07	282	11.10
360 mm	250 x 250	9.84 x 9.84	351	13.82

Laser Controller

Design to meet CDRH standards, the laser controller is remotely connected to the laser marking head by a 1.8-meter (6-foot) umbilical. The umbilical is a combined multi-cable assembly that carries power and control signals to the laser marking head.

The laser controller provides the electrical control of the laser marking system. The controller connects to the 115/230 VAC facility electrical supply to provide power to the laser marking system. The laser controller is also the electrical interface between the laser marking software (installed on the system computer) and the laser marking head. It provides buttons and indicators to control and monitor the laser marking process.

Operator Control Panel

The laser control panel includes the system enable key switch, a start pushbutton, laser off palm button, safety shutter open and shutter close controls, and a laser on (emission) indicator.

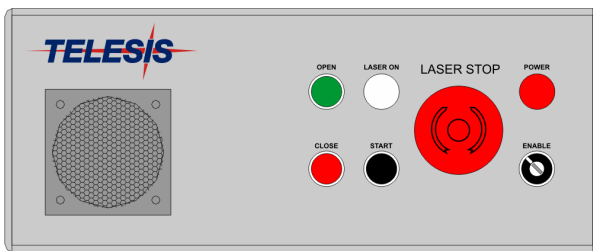

CO₂ Laser Controller – Front Panel

Laser Controller Specifications

Dimensions (W x H x D)492.8 x 200.7 x 508.0 mm
(19.4 x 7.9 x 20.0 in.)

Surrounding Envelope710.0 x 406.0 x 710.0 mm
(28.0 x 16.0 x 28.0 in.)

Weightapprox. 11.82 Kg (27 lbs.)

Coolingair cooled, fan/filter

System PC

The laser system requires an IBM-compatible computer for running the Merlin II LS Laser Marking Software. The PC may be a desktop or a notebook computer and may be supplied by Telesis or by the customer. If the PC is supplied by Telesis, warranty for the computer, computer keyboard, monitor, and peripherals default to the original equipment manufacturer.

Galvo control cards are included, along with interconnect cabling. The laser software is installed and the entire unit is tested as a laser marking system.

The minimum computer requirements are as follows:

- Windows® 2000, Windows® XP or Windows® Vista™ Business
- Telesis Merlin II LS Laser Marking Software
- Pentium® III with recommended RAM as per operating system
- Multi-gigabyte, HDD
- CD-ROM and 3.5 in. External Disk Drives
- SVGA Color Monitor, Mouse, and Keyboard
- Laser/Galvo Controller Board (configured for stationary marking or marking “on-the-fly”)
- Video Card
- One available RS-232 Serial Port
- Two available USB Ports
- Two (minimum) full-height PCI Slots *

Note: If a notebook computer is used, expansion must be used to provide the PCI slots.

System Software

The powerful Telesis Merlin II LS Laser Marking Software is a Windows® based software package that comes standard with the laser marking system. It is a graphical user interface that makes marking pattern design quick and easy. The WYSIWYG (what-you-see-is-what-you-get) interface provides a to-scale image of the pattern as it is created. Just “click and drag” for immediate adjustment to field size, location, or orientation.

The Merlin II LS includes tools to create and edit text (at any angle), arc text, rectangles, circles, ellipses, and lines. Multiple fields may be grouped and saved as a block to form a logo. Existing DXF files can also be imported for marking. Non-printable fields can be created to clearly display a graphical representation of the part being marked.

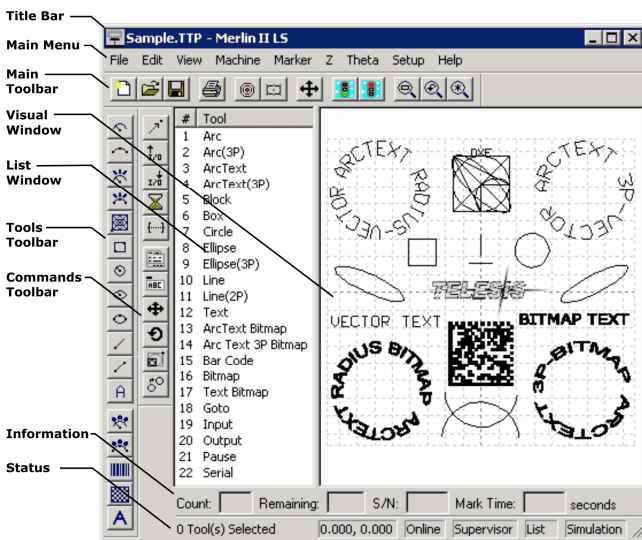

Overview of Merlin-II LS User Interface

Merlin II LS Laser Marking Software Specifications

Operating System	Windows® 2000, Windows® XP, or Windows® Vista™ Business using a Desktop PC or Notebook PC
Font Generation	True Type Fonts
Barcodes and Matrix	2D Data Matrix, PDF417, BC 39, Interleaved 2 of 5, UPCA/UPCE BC 128, Maxi Code, Code 93, QR Code and others
Graphic Formats	Raster and Vector: BMP, GIF, JPG, WMF, EMF, DXF, CUR, ICO
Serialization	Automatic and Manual Input Host Interface Capable
Linear Marking	Scalable with Letter Spacing Control
Arc Text Marking	Scalable and Adjustable
Drawing Tools	Line, Rectangle, Circle, Ellipse

Remote Communications

The communication capability of the marking system software allows you to control the laser from remote I/O devices. Remote communications can be performed by connecting to a Host computer, an optional I/O card, or an optional two-axis Auxiliary Controller.

The rear panel of the controller also provides a connector to monitor output signals that report the status of the shutter, laser emission, and fault conditions.

Host Communications. Remote communications may be executed from a host computer using RS-232 or Ethernet (TCP/IP) connections to the system computer (i.e., the PC running the Telesis laser marking software). The software provides parameters to define the data transmitted to and from the host. For more information on using and configuring these parameters, refer to the *Operation Manual* supplied with the laser marking software.

I/O Card. Telesis offers an optional I/O card that provides six input signals (Start Print, Abort, and four programmable inputs) and six output signals (Ready, Done, Paused, and three programmable outputs). The I/O card is available in the following kits. For more information on using the optional I/O card, refer to the *Telesis Optional I/O Card Installation Supplement* supplied in each of these kits.

Kit #53920 This kit is available for all Telesis laser systems. It includes the I/O Card, SIPs resistor packs (pre-installed), the software driver CD, and installation documentation. This kit does not provide opto-isolated signals. If this kit is used, it is the responsibility of the installer/integrator to provide opto-isolation between remote I/O devices and the I/O card. Refer to the OEM *User's Guide* for signal limitations.

Note: Telesis does not endorse direct connection of I/O signals to the I/O card. Direct connections to high current/high voltage devices will damage the card.

Kit #53928 This kit is available for all laser systems that use the Merlin-II LS Laser Marking Software. It includes Kit #53920 (above), plus the Telesis I/O Interface Module and two cable assemblies. This kit provides opto-isolated signals between remote I/O devices and the I/O card through the Telesis I/O Interface Module. Additional opto-isolator board assemblies or opto-isolated I/O rack assemblies are not required when the interface module is used.

Two-axis Controller. Telesis offers an optional two-axis controller for all laser systems that use the Merlin-II LS Laser Marking Software. The auxiliary controller provides an interface for connecting six input and six output signals to and from the laser marking system, and for connecting the optional auxiliary axes: vertical (Z) axis, rotational (Theta) axis, and linear (L1 and L2) axes.

Environmental considerations must be taken into account when installing the auxiliary controller concerning contaminants and EMI susceptibility. For details, refer to the *Installation/Maintenance Manual* supplied with the controller.

Communications Protocol

Two types of host interface are supported (RS-232 or TCP/IP) and two communication protocols are provided through the Merlin-II LS marking system software (Programmable and Extended).

Programmable Protocol. Programmable protocol provides one-way (receive only) communication with no error checking or acknowledgment of the transmitted data. You may use Programmable protocol to extract a continuous portion of a message string to print. This can be used with a host computer or a bar code scanner. Note that XON/XOFF Protocol applies even when Programmable Protocol is selected.

The Programmable Protocol Message Type identifies the type of message sent from the host. It determines how the marker uses the data it extracts from the host message string when Programmable Protocol is used.

- 49** Message type 49 ("I") overwrites the content of the first text-based field in the pattern with the data extracted from the host message. Note that if the field contains message flags, they will be overwritten, not updated.
- 65** Message type 65 ("A") updates the Offset Angle parameter with the data extracted from the host message. Syntax for the transmitted string is $\pm n$ where \pm is a positive or negative sign and n is an integer that represents the offset angle for the marking window.
- 72** Message type 72 ("H") updates the Offset X/Y parameters with the data extracted from the host message. Syntax for the transmitted string is $\pm X.X, \pm Y.Y$ where \pm is a positive or negative sign, $X.X$ represents the X-axis offset distance, and $Y.Y$ represents the Y-axis offset distance.
- 80** Message type 80 ("P") indicates the data extracted from the host message is the name of the pattern to be loaded.
- 81** Message type 81 ("Q") updates the text in the first query text buffer (buffer 0) with the data extracted from the host message.
- 86** Message type 86 ("V") updates the text in the first variable text field in the pattern with the data extracted from the host message.
- 118** Message type 118 ("v") updates the first text field encountered in the pattern that contains a variable text flag that matches the specified string length.

If the host is providing the Message Type within the transmitted text string, enter "0" in the Message Type parameter text box displayed on the Programmable tab of the Host/Setup window.

- 0** Message type 0 (zero) indicates that the host will provide the message type, field number (if applicable), and data (if applicable). This option allows more flexibility by delegating the message type selection to the host on a message-by-message basis. It also allows you to direct data to specific fields and/or query text buffers.

The host can use Message Type 0 to provide data to the marking system. The marking system will insert data transmitted with the message into the appropriate location.

Communications Protocol (continued)

Extended Protocol. Extended protocol provides two-way communication with error checking. It is designed to provide secure communications with an intelligent host device using pre-defined message formats and response formats. It also provides error checking using a block check code to detect faults in the transmitted messages and to verify the data is properly received.

The Extended Protocol Message Type determines how the marker uses the data it extracts from the host message string or from the marking system software, as applicable.

- I** Message Type "I" can provide data to a text string in the pattern or poll the pattern for data.
- A** Message Type "A" can provide data to the system Offset Angle parameter for the marking window or poll the system for data.
- E** Message Type "E" allows the host to take the machine offline. It also provides the option of displaying an error message box with the provided data string.
- V** Message Type "V" can provide data to a variable text string in the pattern or poll the pattern for data.
- P** Message Type "P" can load a pattern or poll the system for the current pattern name.
- O** Message Type "O" places the marker online. This allows a host computer to reset. For example, this may be used to recover from a power outage when the marker is unattended.
- G** Message Type "G" initiates a print cycle.
- Q** Message Type "Q" can provide data to the system query text buffer or poll the system for data.
- H** Message Type "H" can provide data to the system X/Y Offset parameters or poll the system for data.
- S** Message Type "S" is used to poll the system for the machine status. The machine status is returned to the host in an eight-character hexadecimal mask.
- I** Message Type "I" is used to poll the system for the I/O status.

TRADEMARKS

Telesis and **Merlin** are registered trademarks of Telesis Technologies, Inc. in the United States and/or other countries.

Pentium is a registered trademark of Intel Corporation in the United States and other countries.

Plexiglas is a registered trademark of Arkema, Inc..

Vista is a trademark of Microsoft Corporation in the United States and other countries.

Windows is a registered trademark of Microsoft Corporation in the United States and other countries