

SYSTEM OVERVIEW

The Telesis® SC2000/470 TeleScribe® Marking System permanently inscribes messages into a variety of materials such as steel, aluminum, and plastic. Marking is accomplished by a hardened pin that is pneumatically pressed into the surface being marked. The shape, size, and location of the inscribed characters are determined by the user through the system software. As the marking head moves the pin cartridge through the X/Y axes, the tip of the extended pin displaces the material being marked, thereby forming continuous-line characters. The system software automatically controls pin extension and retraction to mark the message.

The system is compliant with UL, CSA, CE, and RoHS specifications.

The **SC2000 Marking Head** includes the mechanical motion components to position the marking pin at precise X/Y positions and the pneumatic components to extend the pin from, and return the pin to the pin cartridge.

The marking head is an X and Y traversing mechanism. Using two stepper motor drives, it accurately and rapidly positions the pin at coordinate-defined locations in the marking window within .025mm (.001"). The SC2000 accommodates the rigorous and rapid positioning of the marking pin through a system of rigid rails and ball bearing saddles, timing belts, and direct-drive, toothed pulleys.

The floating pin design permits high quality, consistent marks on irregular, slightly curved surfaces. It also accommodates applications where marking surfaces cannot be positioned at a consistent distance from the marker.

The **Marker Cable** connects the marking head to the controller. The head cable is a highly flexible cable. The standard cable length is 4 m (13 ft.). Optional cable extensions are available for greater distances.

Lightweight **Pin Cartridges** are provided for the marking pins. The machined cartridges, piloted to resist shear loads, offer long life with little maintenance. The cartridge is attached to the marking head with four bolts to allow for easy removal, cleaning, and pin replacement.

Marking Pins for the SC2000 are available in various cone angles radius tips, and piston diameters. An optional, diamond-tip pin is also available. Refer to the *SC2000 Marking Head Dimensions* drawing (on next page) for maximum pin extension (pin stroke).

The **Filter/Regulator Unit** includes two regulators with pressure gauges to control the drive air and return air. The unit contains a filter to help remove contaminants from the supply air. Two air lines connect the regulated air to the marking head. Drive air extends and holds the impact pin while scribing; return air pushes it back into the cartridge. The standard drive/return air lines are 4 m (13 ft.) long made of 6 mm tubing.

The **TMC470 Controller** contains an integrated keyboard with an LCD display. It provides a text-only operator interface and allows full operational control of the SC2000 marking head. The back panel provides the electrical interface for connecting to optional, remote I/O sources. Refer to *TMC470 Controller Specifications* for details.

SC2000/TMC470 Marking System

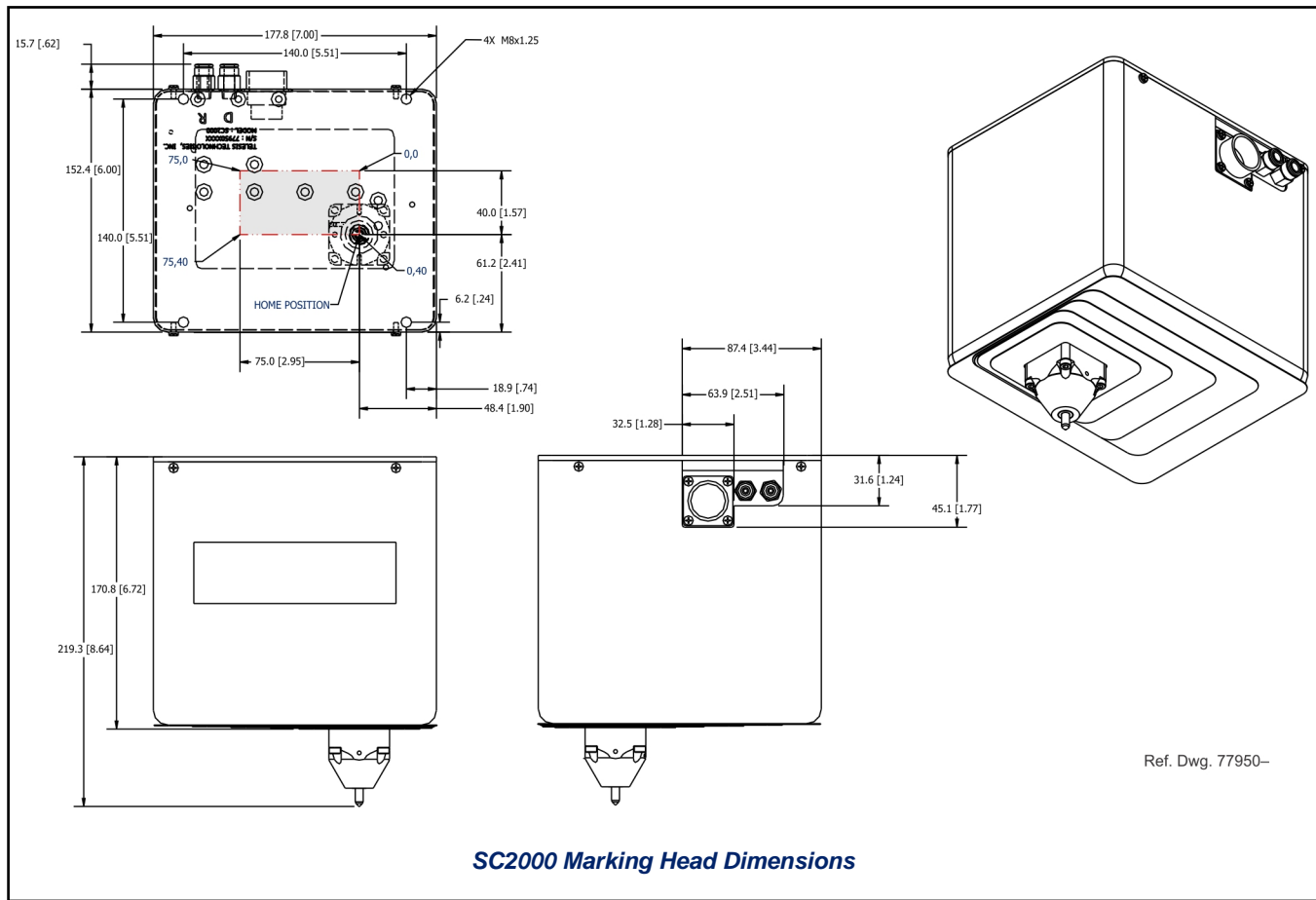

SYSTEM SETUP

The drawn sheet metal cover allows for fixture-mounting. When designing the fixture, allow for 3-axis adjustment to aid in horizontal, vertical, and lateral alignment of the marking head.

1. Mount marking head to a suitable, rigid structure. Refer to the SC2000 Marking Head Dimensions drawing for dimensions and hole locations.

CAUTION

Mounting bolts must not extend into the marking head more than 10mm (.375 in.).

2. Mount filter/regulator assembly using brackets provided within 4 m (13 ft.) of the marking head.
3. Connect Drive Air line and Return Air line to Drive and Return fittings on marking head.
4. Connect supply air to input port on filter/regulator assembly.
5. Locate controller as close as practical to the marking head. Standard marking head cable length is 4 m (13 ft).

CAUTION

The TMC470 is not a sealed unit. Protect it from potentially damaging conditions and contaminants. Do not block vents in bottom of case. Ensure the marking system is electrically isolated from any devices that may generate extreme electromagnetic interference (EMI).

6. Install controller as a table-top, wall-mounted, panel-mounted, or enclosure-mounted unit, as applicable.
7. Ensure controller power switch is OFF.
8. Connect marker cable to marking head and to controller.
9. Connect power cable to controller.
10. Position controller power switch to ON.
11. Start marking system software.
12. Adjust pin stroke, drive air, and return air for marking depth.

SYSTEM OPTIONS

- Marking Head Extension Cables
- Marking Head Mounting Post
- TMC470 Controller Wall-mounting Bracket Kit
- TMC470 Controller Panel-mounting Bezel/Bracket Kit
- TMC470N NEMA® Enclosure
- Bar Code Scanner or Bar Code Wand with Cable
- Foot Switch (Start Print) or Pushbutton Station (Start/Abort)
- Backup Utility Software
- Upgrade Utility Software
- Logo/Font Generator Software

SC2000 MARKING HEAD

Specifications

The SC2000 marking head specifications are subject to change without prior notice.

Dimensions	refer to the <i>SC2000 Marking Head Dimensions</i> drawing
	Note: Overall dimensions of marking head may be reduced for custom applications.
Weight	6 kg (13.2 lb.)
Operating Temp.....	0° to 50° C (32° to 122° F), non-condensing
Air Supply	Clean and dry, 4.2 to 8.3 bar (60 to 120 psig)
Air Consumption	0.04 SCFM (idle) 0.60 SCFM (marking)
Marking Area	75 x 40 mm (2.95 x 1.57 in.)
Pin Material.....	Tungsten Carbide (optionally diamond-tipped)

SC2000 MARKING HEAD (continued)

Marking Characteristics

The SC2000 can produce characters as small as 1.5 mm (.06"), printed at any angle within the 75 x 40 mm (2.95 x 1.57 in.) X/Y marking window. Character strings may be marked at any angle (0° to 359° rotation) in 1° increments. The system can also print arcs and arc text.

Marking Speeds

Marking speeds vary widely, depending on character size. For example, 3mm (.125") high characters may be printed at two characters/sec. (max). Smaller characters may be printed faster; larger characters may require longer printing times. Specific marking times can be verified by a Telesis representative.

Pin Life

Pin life depends largely on the type of material being marked, how hard or abrasive it is, and the required marking depth.

Marking Noise

The SC2000 provides virtually silent marking with a maximum noise level approximately 72 DBA.

Marking Depth

The depth of mark may be adjusted by changing the drive air pressure. Maximum marking depths vary widely, depending on the material being marked, the thickness of the material, the marking pin selection, and the air pressure setting. In cold rolled steel with a thickness of .75 mm (.030") or more, marking depths up to .05 mm (.002") may be achieved. In aluminum with a thickness of 1 mm (.040") or more, marking depths up to .075 mm (.003") may be achieved. In thinner materials, the maximum marking depth may increase significantly. Specific marking depths can be verified by a Telesis representative.

SC2000/TMC470 Marking System

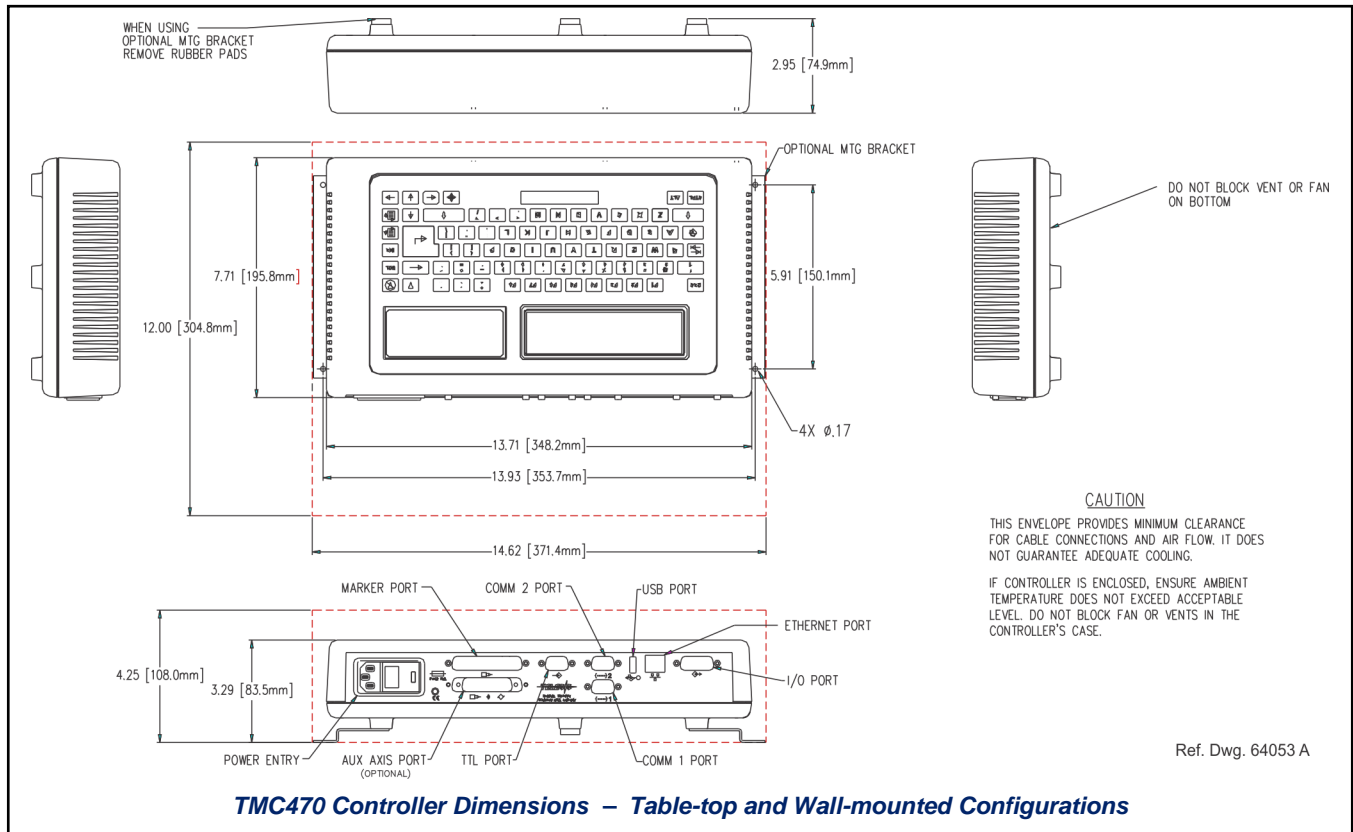

TMC470 CONTROLLER

The TMC470 controller may be installed as a table-top unit, a wall-mounted unit, a panel-mounted unit, or an enclosure-mounted unit. All configurations provide features and connectivity for external communications. Differences occur only in the mounting configuration.

TMC470 Specifications

The TMC470 Controller specifications are subject to change without prior notice.

Compliance	CE, RoHS
Configurations...	Table-top, Wall-mounted, Panel-mounted, or Enclosure-mounted
Rating	NEMA 1 (I.P. 30) table-top or wall-mounted NEMA 12 (I.P. 65) panel-mounted using appropriate customer-supplied panel NEMA 12 (I.P. 65) enclosure-mounted using Telesis-supplied TMC470N enclosure
Dimensions.....	refer to the appropriate <i>TMC470 Controller Dimensions</i> drawing
Weight	3.69 lb. (1.68 kg) controller only 3.90 lb. (1.77 kg) with wall-mount kit 5.52 lb. (2.51 kg) with panel-mount kit 28.1 lb. (12.77 kg) with TMC470N enclosure

TMC470 Specifications (continued)

Operating Temp	32° to 122° F (0° to 50°C)
Operating Humidity ..	10% to 80% non-condensing
Cooling.....	Internal, thermostat-controlled fan
Power Requirements .	95 to 250 VAC, 2 amps, 50-60 Hz, single phase
Communications	TTL, Discrete I/O, RS232, RS485, TCP/IP, and USB (data backup and transfer)
Input Signals	Twelve (12) total, optically isolated 8 dedicated, 1 programmable, 3 available 10 VDC (minimum voltage) 30 VDC (maximum voltage) 12 to 24 VDC (nominal voltage) 2.3 mA @ 12VDC; 4.9 mA @ 24VDC (nominal current)
Output Signals.....	Six (6) total, optically isolated 4 dedicated, 2 available 0.25 amps (maximum current) 0.50 ohms (maximum On resistance) 40 VDC (maximum line voltage) 12 to 24 VDC (nominal line voltage)

SC2000/TMC470 Marking System

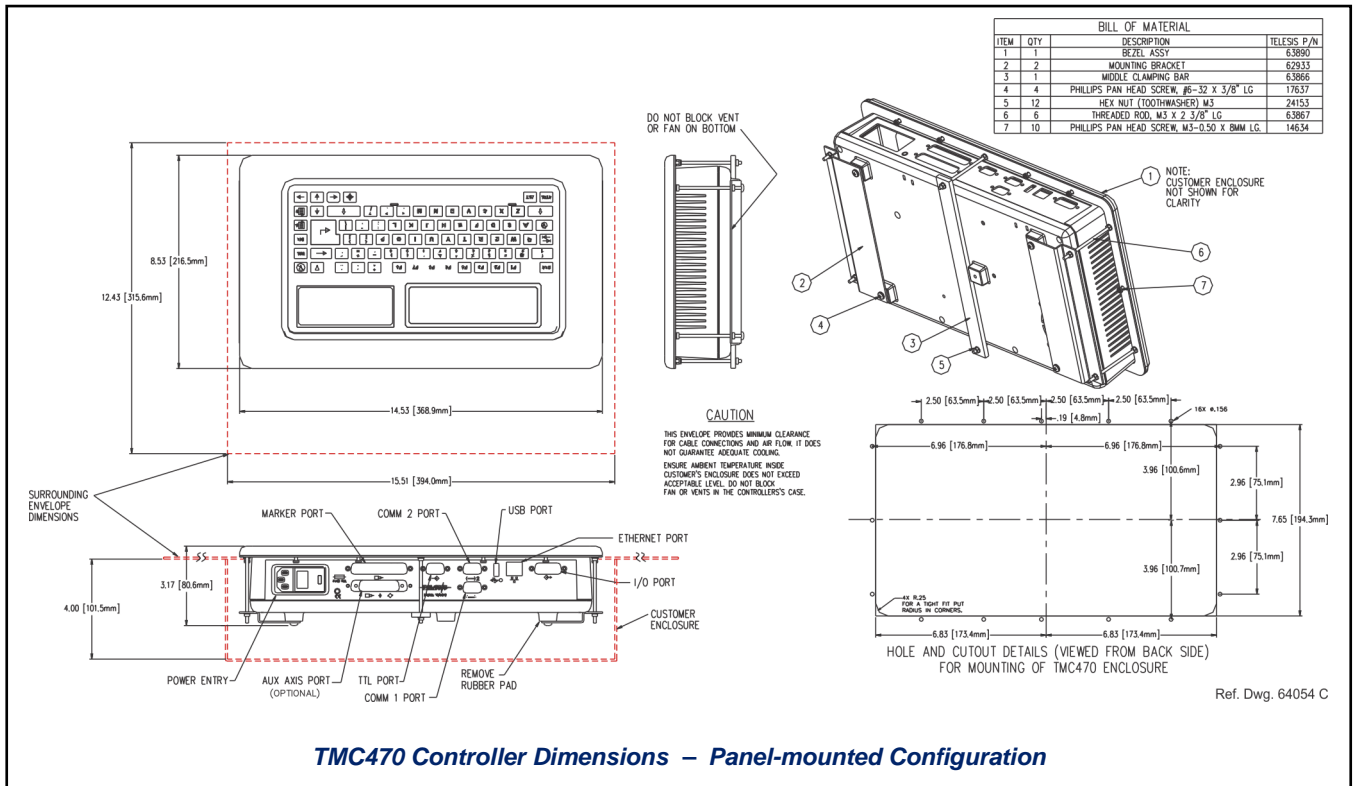

TMC470 Controller Dimensions – Panel-mounted Configuration

Environmental Considerations

The following environmental considerations must be taken into account when installing the TMC470 Controller.

Contaminants. The vented TMC470 is rated NEMA 1 (IP30) and contains a thermostatically-controlled, variable speed fan. Accordingly, in environments where solid and/or liquid contaminants are present, the possibility exists that these contaminants can be drawn into the TMC470 controller and possibly result in failure. For that reason, in these types of environments, the controller must be located in a sealed industrial enclosure. To facilitate such installations, Telesis offers an optional panel mounting kit for use with an appropriate customer-supplied panel or enclosure. Telesis also offers an optional TMC470N NEMA 12 (I.P. 65) enclosure in which the controller can be mounted.

EMI Susceptibility. Although the system has been found to be in compliance with pertinent susceptibility standards, care should be taken when installing near welders and other extreme generators of electromagnetic interference (EMI). Particular care should be taken to ensure welder currents are not injected through the marking head chassis. The marking head chassis is connected to the electrical service earth ground through the marking head cable. The marking head should be electrically isolated from all surfaces which could become part of a welder current path.

TMC470-based System Software

The system software is permanently installed in the controller. It provides the user interface for the operator to control the marker. The software also provides a library for storing, loading, and editing user-defined patterns. Patterns are files stored in the controller's memory. Depending on the size of the pattern files, the controller can store up to 200 patterns. Each pattern contains one or more fields; each field defines a single object. Printable objects may be created to define text strings, arc-text strings, geometric shapes, and graphics. Non-printable objects may be defined to specific commands to the marker (e.g., Pause, Go to, Input, or Output). Printable text fields may include alphanumeric characters, symbols, and special message flags. Message flags automatically insert data into the text string, such as serial numbers, times, dates and user-defined codes.

SC2000/TMC470 Marking System

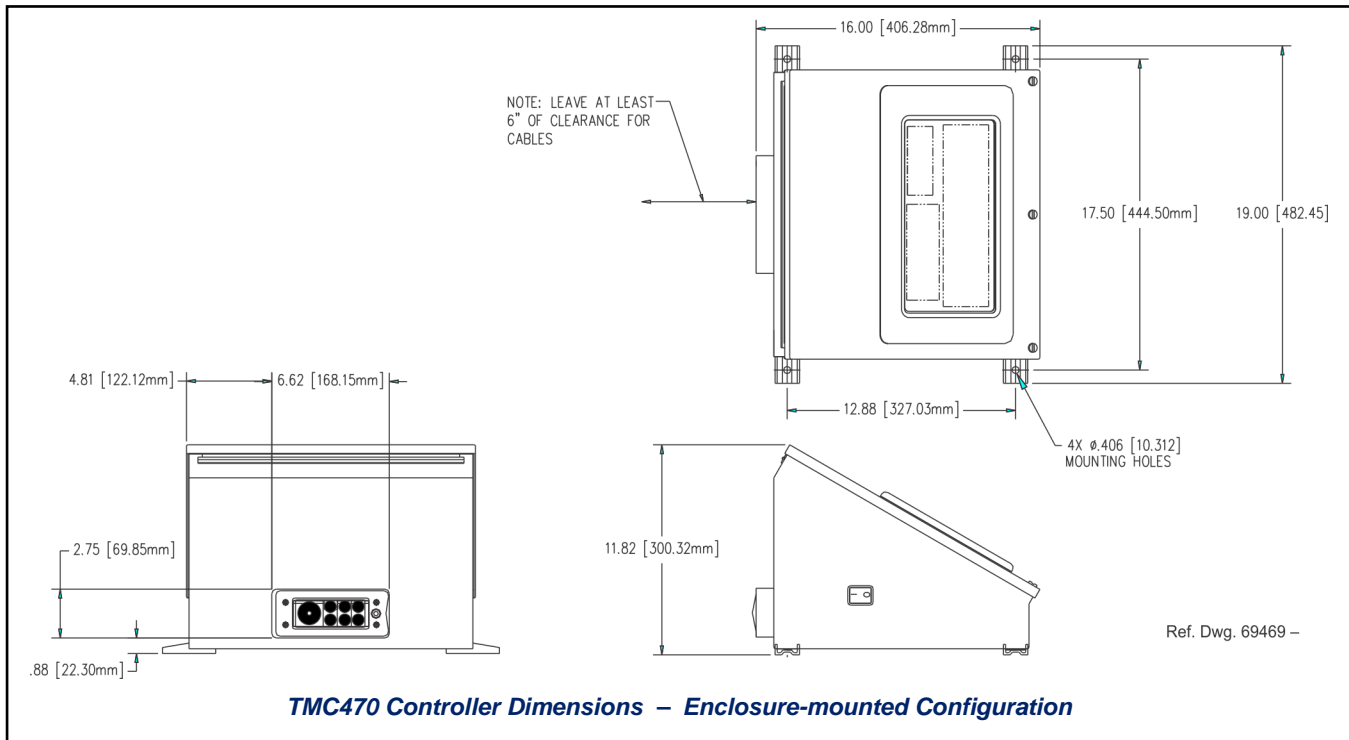

Interface Panel

The back panel of the controller provides various ports for connecting the marker, host computers, logic controllers, optional accessories, and remote I/O devices. See below.

Serial Interface. The Comm 1 and Comm 2 Ports allow connection to remote serial devices such as a host computer or a bar code scanner. See *Host Communications* for details.

Discrete I/O Interface. The optically-isolated I/O Port allows you to connect a Programmable Logic Controller (PLC) or other DC I/O source for remotely controlling marker operations. See *Discrete I/O Controls* for details.

TTL Interface. The TTL Port allows the system to connect with a simple contact closure circuit such as a remote push button station or foot pedal switch. These types of devices can remotely control Start Print and Stop Print operations.

TCP/IP Interface. The Ethernet Port typically connects to a PC over a local area network (LAN). It allows you to define the controller as a client or a server socket using Telesis Extended Protocol. See *Host Communications* for details.

USB Interface. The USB Port allows you to connect a memory stick/flash drive for pattern storage/retrieval and for software upgrades.

Discrete I/O Controls

The TMC470 is configured for 12 VDC to 24 VDC I/O only and is provided to connect a PLC or other DC I/O source. The optically-isolated I/O Port allows you to remotely select and load patterns, start printing, stop printing, place the marker online, and monitor the system output signals. Cable connectors and connector pins are supplied with the controller for constructing appropriate interface cables.

Input Signals. These input signals provide the following controls:

- INPUT COMM For all inputs (+ or – supply)
- START PRINT Begins print cycle
- STOP Stops the print cycle
- SEL_0 thru _6 * Remotely selects & loads up to 127* pattern files
- SPARE_1, 2, 3 Three (3) spares for custom applications

* System software allows SEL_6 signal to be configured for remotely selecting patterns or for remotely placing the marker online. If used for marker online, pattern selection is reduced to 63 patterns (max).

Output Signals. These output signals indicate the following states:

- OUTPUT COMM ... For all outputs (+ or – supply)
- DONE Print cycle is complete
- READY System ready for message or for start print command
- PAUSED System paused (waiting timeout or command)
- NO FAULT System status (normal or fault detected)
- SPARE_1, 2 Two (2) spares for custom applications

Host Communications

The marking system software allows you to configure communication parameters to transmit and receive data to and from a host computer. To provide maximum integration flexibility, the system software supports RS-232 and RS-485 serial interfaces and Ethernet TCP/IP interfaces. The system software also provides two protocol choices: Programmable Protocol and Extended Protocol.

RS-232 Interface. The serial (RS-232) communications interface is most often used with remote devices such as host computers, terminals, or bar code scanners. The Comm 1 RS-232 interface supports both Telesis Extended Protocol and Telesis Programmable Protocol. The Comm 2 RS-232 interface supports only Telesis Programmable Protocol.

RS-485 Interface. The RS-485 interface is normally used for long transmission distances or multi-drop networks of up to 31 TMC470 controllers. You must use Telesis Extended Protocol with the RS-485 interface.

The following describes the serial data character format on all transmissions to and from the TMC470 Controller.

- Asynchronous
- 1200, 2400, 4800, 9600, 19200, 38400, or 115200 Baud
- 1 or 2 Stop Bits
- 7 or 8 Data Bits
- None, Even or Odd Parity

TCP/IP Interface. The Ethernet (TCP/IP) interface is most often used with host computers communicating over a local area network (LAN). You must use Telesis Extended Protocol with the TCP/IP interface.

The Port parameter identifies the host computer socket that is assigned to the marking system. If more than one marking system is installed in a network configuration, each system must use a separate and unique port number. The Address parameter identifies the IP address of the host computer. The marking system software supports both fixed addressing and dynamic addressing.

Programmable Protocol. Use this protocol where very simple one-way communications are required (such as with bar code scanners). Programmable Protocol provides no error checking or acknowledgment of the transmitted data. Note that XON/XOFF Protocol applies even when Programmable Protocol is selected.

Starting Character specifies where the software begins to count character positions. This number must be entered in decimal format (e.g., "2" for ASCII Start of Text "STX").

Terminating Character identifies the end of transmitted string (usually "13" for ASCII carriage return character).

Character Position counted from the starting character ignoring all characters preceding it.

Character Length accepts variable length messages (if set to 0) or messages of a pre-specified, fixed number of characters.

Ignore Character identifies the character to ignore when sent from the host (usually "10" for ASCII line feed character).

Message Type allows message-type recognition which defines how the marking system will use data it receives from the host.

- 1** Message type 1 overwrites the *first line of the first text field* with data extracted from the host
- P** Message type P loads a specific pattern identified by data extracted from host
- Q** Message type Q updates the text in the *first query buffer* with data extracted from the host
- V** Message type V updates the *first variable text flag* found in the pattern with data extracted from the host
- 0** Message type 0 (zero) indicates that host will provide message type, field number (if applicable), line number (if applicable), and data; delegates message type selection to the host on message-by-message basis. The host message must use the format:

Tnn<string>

where:

T = 1, P, Q, or V to indicate message type

nn = two-digit field number or query text buffer where data will be placed.

Note: Not used with Message Type P.

<string>= For Message Type P, indicates the pattern name to be loaded.

For Message Types 1, Q, or V, indicates the data to be inserted into the field or the query text buffer, as applicable.

SC2000/TMC470 Marking System

Host Communications (continued)

Extended Protocol. This protocol selection includes error checking and transmission acknowledgment. It should be used in applications where serial communication is a vital part of the marking operation. All communications are carried out in a parent/child relationship with the host being the parent. Only the host has the ability to initiate communications. If the host does not receive a response within three seconds, it should re-transmit its original message. If no response is received after three tries, it should declare the link to be down.

The following describes the Extended Protocol message format as sent from the host to the TMC470 controller.

SOH TYPE [##] STX [DATA] ETX BCC CR

where:

SOH ASCII Start of Header character (001H). The controller ignores all characters received prior to the SOH.

TYPE A single, printable ASCII character that defines the meaning (type) and content of the message downloaded from the host, where:

- 1** Message Type 1 overwrites a specific field in currently loaded pattern with data supplied in the host message. See [DATA] for details.
- P** Message Type P specifies the pattern name to be loaded for printing. See [DATA] for details.
- Q** Message Type Q updates a specific query buffer with data supplied in the host message. See [DATA] for details.
- V** Message Type V updates the variable text in a specific text field of the currently loaded pattern with data supplied in the host message. See [DATA] for details.
- O** Message Type O resets marker and places it online
- G** Message Type G initiates a print cycle to mark the currently loaded pattern
- I** Message Type I requests the marker return the status of standard output and input signals. The system will return a hexadecimal code for the 6 output signals and 12 input signals in the following format:

O O ; I I I

where:

bit 1	READY	0x01
bit 2	DONE	0x02
bit 3	PAUSED	0x04
bit 4	NO_FAULT	0x08
bit 5	SPARE_1	0x10
bit 6	SPARE_2	0x20
bit 1	START	0x001
bit 2	STOP	0x002
bit 3	SEL_0	0x004
bit 4	SEL_1	0x008
bit 5	SEL_2	0x010
bit 6	SEL_3	0x020
bit 7	SEL_6 *	0x040
bit 8	SEL_4	0x080
bit 9	SEL_5	0x100
bit 10	SPARE_1	0x200
bit 11	SPARE_2	0x400
bit 12	SPARE_3	0x800

* Input SEL_6 may be configured to place machine online (the default option) or for Remote Pattern Selection.

[##] Optional two-digit ASCII number that specifies the Station ID of the controller when used in multi-drop network applications. The Station ID may range from 00-31. Note that "00" is reserved for applications where only one controller is used. In such applications, this field may be eliminated and "00" will be assumed.

STX ASCII Start of Text Character (002H).

[DATA] Optional character string that may be required for certain message types (e.g., Type 1, P, Q, and V).

Typically, data is sent in the format:

nn<string>.

where:

nn = two-digit field number or query text buffer where data will be placed.

Note: Not used with Message Type P.

<string>= For Message Type P, indicates the pattern name to be loaded.

For Message Types 1, Q, or V, indicates the data to be inserted into the field or the query text buffer, as applicable.

ETX ASCII end of text character (003H).

BCC Optional Block Check Code that is generated and sent to improve link reliability by providing fault detection. The BCC is calculated by taking an eight bit addition of the TYPE and DATA TEXT characters and transmitting them as a three digit ASCII decimal number in the range from 000 to 255. If the sum is greater than 255, the most significant bit overflows and is discarded.

CR ASCII Carriage Return Character (00DH).

TRADEMARKS

Telesis, **PINSTAMP**, and **Merlin** are registered trademarks of Telesis Technologies, Inc. in the United States.

NEMA is the registered trademark and service mark of the National Electrical Manufacturers Association.

Pentium is a registered trademark of Intel Corporation in the United States and other countries.

Windows and **Vista** are registered trademarks of Microsoft Corporation in the United States and other countries.