

System Overview

The Telesis® TMP3200E/420 PINSTAMP® marking system permanently prints messages into a variety of materials such as steel, aluminum, and plastic. A hardened pin is accelerated to indent dot matrix characters into the item being marked. Character shape, size, density, and location are determined by the user through the marking system software.

The **TMP3200E Marking Head** is an electromechanical marker. The internal, mechanical components position the pin cartridge and an electric solenoid fires the marking pin. A spring returns the pin to its idle position within the cartridge. The marking head moves the pin cartridge through X- and Y-axis motions to reach the correct position for each dot of the characters to be marked. The system software automatically controls pin extension to mark the message.

The TMP3200E marking head is an X/Y-traversing mechanism. Using two stepper motor drives, it accurately and rapidly positions the pin at coordinate-defined locations in marking window within .03175 mm (.00125"). The marker accommodates the rigorous dynamics of impacting, rebounding, and rapid positioning of the marking pin through a system of rigid rails and ball bearing saddles, timing belts, and direct-drive, toothed pulleys.

The pin design permits high quality, consistent marks on irregular, slightly curved surfaces. It also accommodates applications where marking surfaces cannot be positioned at a consistent distance from the marker.

The **Marker Cable**, pre-wired to the marking head, connects the marker to the controller. The highly flexible cable is 4m (13 ft.) long. Optional extension cables are available for greater distances.

The **Pin Cartridge**, machined from engineered plastic materials, offers long life with little maintenance. Screws attach the pin cartridge to the marking head for easy removal, cleaning, and pin replacement.

The **25XLE-series Marking Pins** are made of tungsten carbide and are available in 30° and 45° cone angles.

The **TMC420 Controller** includes an integrated keyboard with a four line LCD display. It provides the electrical interface and software control of the TMP3200E marking head. (Refer to *TMC420 Controller Specifications* for details.)

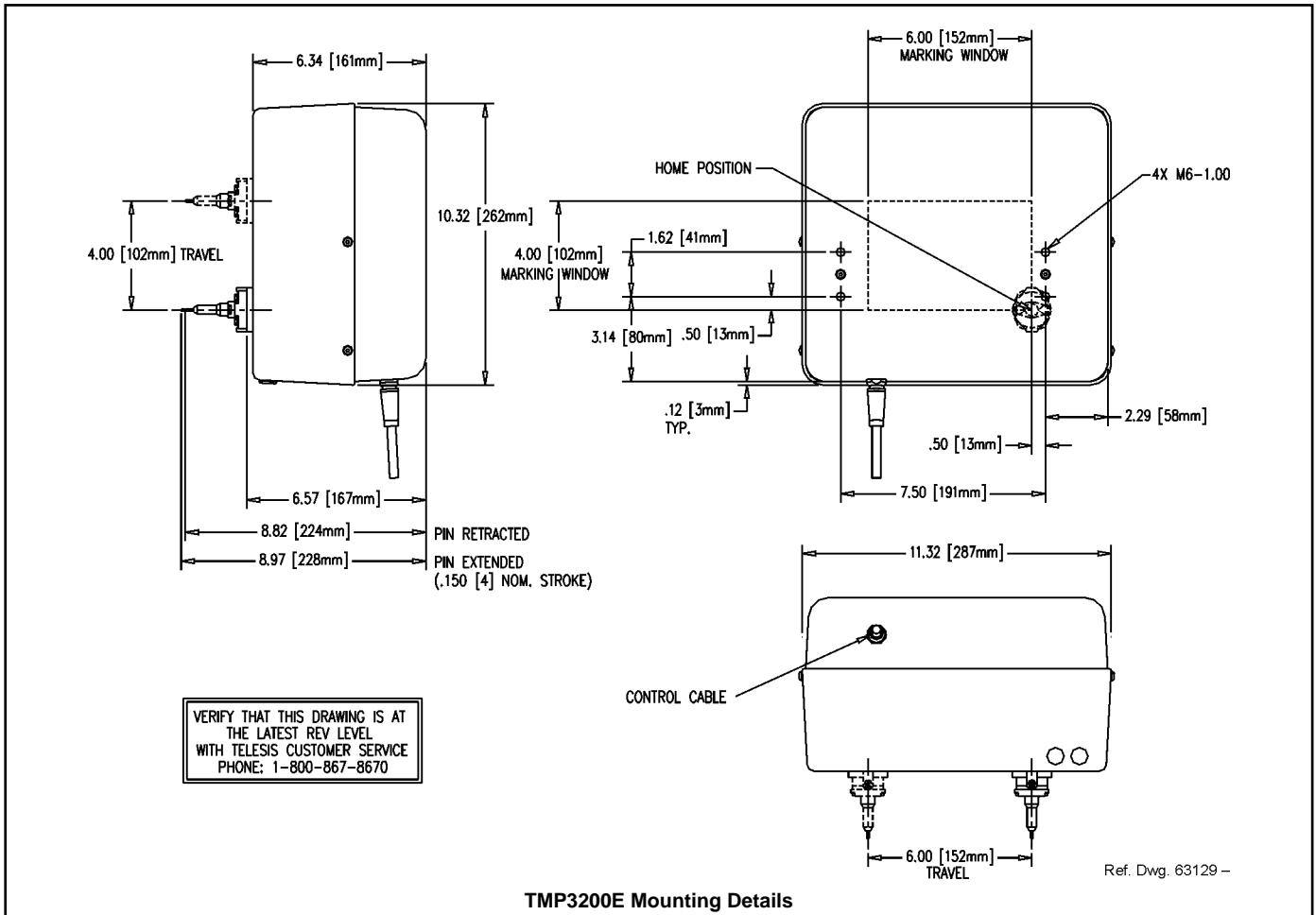

System Setup

When designing a fixture, allow for 3-axis adjustment to aid in horizontal, vertical, and lateral alignment of the marking head.

1. Mount marking head to optional tool post assembly (or other suitable fixture) using four M6-1.00 x 20 mm bolts.

Note: The marker may be mounted in any orientation, but preferred installation is with the pin pointed *downward*. Mounting the marker with the pin pointing upward is strongly discouraged because debris may fall into the marking head cavity.

2. Adjust pin stroke for proper pin impact depth.

Note: The TMC420 is not a sealed unit. Protect it from potentially damaging conditions and contaminants. Do not block case vents. Ensure the marking system is electrically isolated from any devices that may generate extreme electromagnetic interference (EMI).

3. Locate controller as close as practical to marking head. Standard marker cable length is 4 m (13 ft.).
4. Ensure controller power switch (on back panel) is OFF; connect power cable to controller.

5. Connect marker cable from marking head to controller; tighten securely.
6. Position controller power switch to ON (on back panel) to start the system software.

System Options

- Manually Adjustable Tool Post Assembly
- Electromechanical Tool Post with Auto Sense Capability
- RD3 and RD5 Theta Axis Rotational Fixtures
- Marking Head Extension Cables
- TMC420 Controller Mounting Bracket Kit
- TMC420 Controller NEMA 12 Enclosure
- Bar Code Scanner
- Bar Code Wand
- Foot Switch (Start Print)
- Pushbutton Station (Start/Abort)
- Backup Utility Software
- Upgrade Utility Software
- Logo/Font Generator Software

TMP3200E Marking Head

TMP3200E Specifications. The TMP3200E marking head specifications are subject to change without prior notice.

DIMENSIONS	<i>see TMP3200E Mounting Drawing</i>
WEIGHT	6.14 kg (13.5 lb.), marking head and cable
OPERATING TEMP.	0° to 50° C (32° to 122° F), non-condensing
MARKING AREA	150 x 100 mm (6.0 x 4.0")
PIN TYPES	25XLE-series
PIN MATERIAL	Tungsten Carbide

Pin Life. Pin life depends largely on the type of material being marked, how hard or abrasive it is, and the required marking depth. On typical metals with a hardness of Rockwell Rb47, marking at a depth of .127 mm (.005"), carbide pins average approximately 9 million impressions before needing sharpened.

Marking Characteristics. The TMP3200E can produce characters as small as .76 mm (.030"), printed at any angle within the marking window. Printing resolutions range from 4 to 79 dots per cm (10 to 200 dots per inch) for an engraved look.

Marking Speeds. Generally, the system will mark 2.5 characters per second using 5x7 font, 3 mm (.118") high, 2mm (.080") wide characters. Speeds will vary slightly depending on the selected character size, style, and dot density. Specific times can be verified by a Telesis representative.

Marking Noise. Although every attempt is made to reduce noise, the material being marked significantly influences the noise level. For example, marking a solid lead block produces less noise than marking a thin-walled steel pipe.

Marking Depth. The TMP3200E can obtain a marking depth of .127 mm (.005") in mild steel (Rb53) using a 25XLE carbide pin with a 45° cone angle. The depth of mark can be adjusted over a significant range by changing the impact distance (pin stroke) or the impact force (software parameter). Specific depths can be verified by a Telesis representative.

TMC420 Controller

Configurations. Three models of the TMC420 are available for use with the TMP3200E: the TMC420 table-top controller, the TMC420P panel-mounted controller, and the TMC420N enclosure-mounted controller. All controllers provide the same software features and the same connectivity for external communications. Differences occur only in their mounting configurations.

TMC420 Specifications. The TMC420 controller specifications are subject to change without prior notice.

DIMENSIONS	<i>refer to TMC420 Mounting Drawing</i>
RATING	NEMA 1 (I.P. 30)
WEIGHT	2.15 kg (4.75 lb.)
OPERATING TEMP.	0° to 50°C (32° to 122° F), non-condensing
POWER REQUIREMENT	95-130 VAC, 2 amps, 50-60 Hz single phase 200-250 VAC, 1 amp, 50-60 Hz single phase
I/O VOLTAGE	12 to 24 VDC (customer-supplied)

TMC420P Specifications. The TMC420 controller specifications are subject to change without prior notice.

DIMENSIONS	<i>refer to TMC420P Mounting Drawing</i>
RATING	NEMA 1 (I.P. 30) stand-alone NEMA 12 (I.P. 65) installed
WEIGHT	3.10 kg (6.8 lb.)
OPERATING TEMP.	0° to 50°C (32° to 122° F), non-condensing
POWER REQUIREMENT	95-130 VAC, 2 amps, 50-60 Hz single phase 200-250 VAC, 1 amp, 50-60 Hz single phase
I/O VOLTAGE	12 to 24 VDC (customer-supplied)

TMC420N Specifications. The TMC420 controller specifications are subject to change without prior notice.

DIMENSIONS	<i>refer to TMC420N Mounting Drawing</i>
RATING	NEMA 12 (I.P. 65)
WEIGHT	12.77 kg (28.1 lb.)
OPERATING TEMP.	0° to 50°C (32° to 122° F), non-condensing
POWER REQUIREMENT	95-130 VAC, 2 amps, 50-60 Hz single phase 200-250 VAC, 1 amp, 50-60 Hz single phase
I/O VOLTAGE	12 to 24 VDC (customer-supplied)

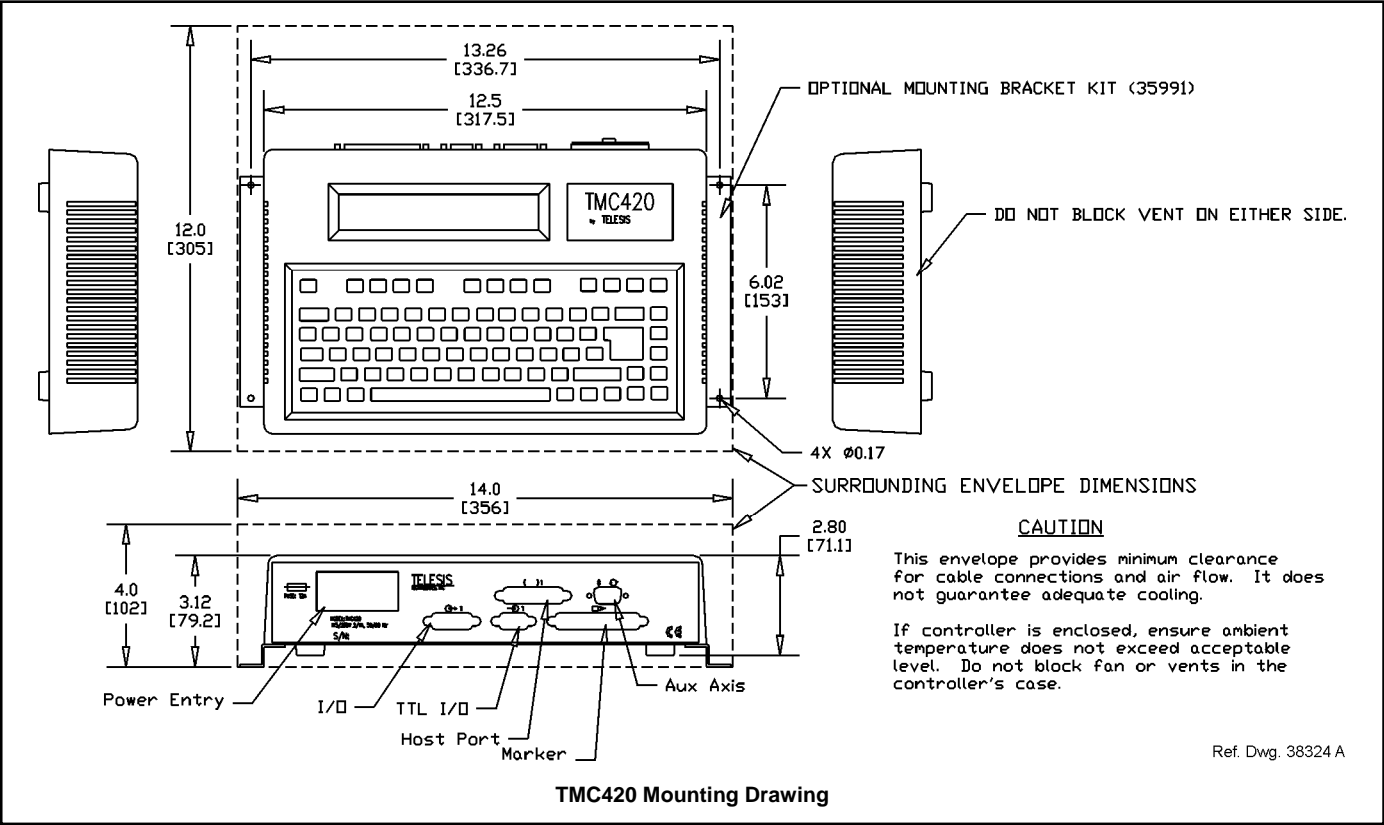

Environmental Considerations. The following environmental considerations must be taken into account when installing the TMC420 controller.

Contaminants. The vented and fan-cooled TMC420 is rated NEMA 1 (IP30). Accordingly, in environments where solid and/or liquid contaminants are present, the possibility exists that these contaminants can be drawn into the TMC420 controller and possibly result in failure of a number of electronic components. For that reason, in these types of environments, the controller must be located in a sealed industrial enclosure. To facilitate such installations, Telesis offers the panel-mounted TMC420P and the enclosure-mounted NEMA 12 (IP65) rated TMC420N. Telesis also offers an optional NEMA 12 (IP65) enclosure in which the TMC420 can be mounted for applications that do not require frequent operator access to the TMC420 display and keyboard.

EMI Susceptibility. Although the system has been found to be in compliance with pertinent susceptibility standards, care should be taken when installing near welders and other extreme generators of electromagnetic interference (EMI). Particular care should be taken to ensure welder currents are not injected through the marking head chassis. The marking head chassis is connected to the electrical service earth ground through the marking head cable. The marking head should be electrically isolated from all surfaces which could become part of a welder current path.

System Software. The system software is permanently installed in the controller. It provides the user interface for the operator to control the marker. The software also provides a library for storing, loading, and editing user-defined patterns. Patterns are files stored in the controller's memory. The controller can store up to 75 patterns. Each pattern contains one or more fields. A field defines a single object and how it will be printed. Fields may define text strings, arcs, arc text strings, Go-To or Pause commands, or machine-readable data matrix symbols. Text fields may include alphanumeric characters, symbols, and special message flags. The message flags automatically insert data into the text string, such as serial numbers, times, and dates.

Interface Panel. The interface panel provides various ports for connecting the marker, host computers, logic controllers, or optional accessories.

Serial Interface. The Host Port is used for RS-232 and RS-485 communications with serial devices such as a host computer or bar code scanner. Up to 31 controllers may be used in a multi-drop configuration using the RS-485 interface. The host computer can load patterns, download messages, place the marker on/offline, and monitor system errors. (See *Serial Communications* for details.)

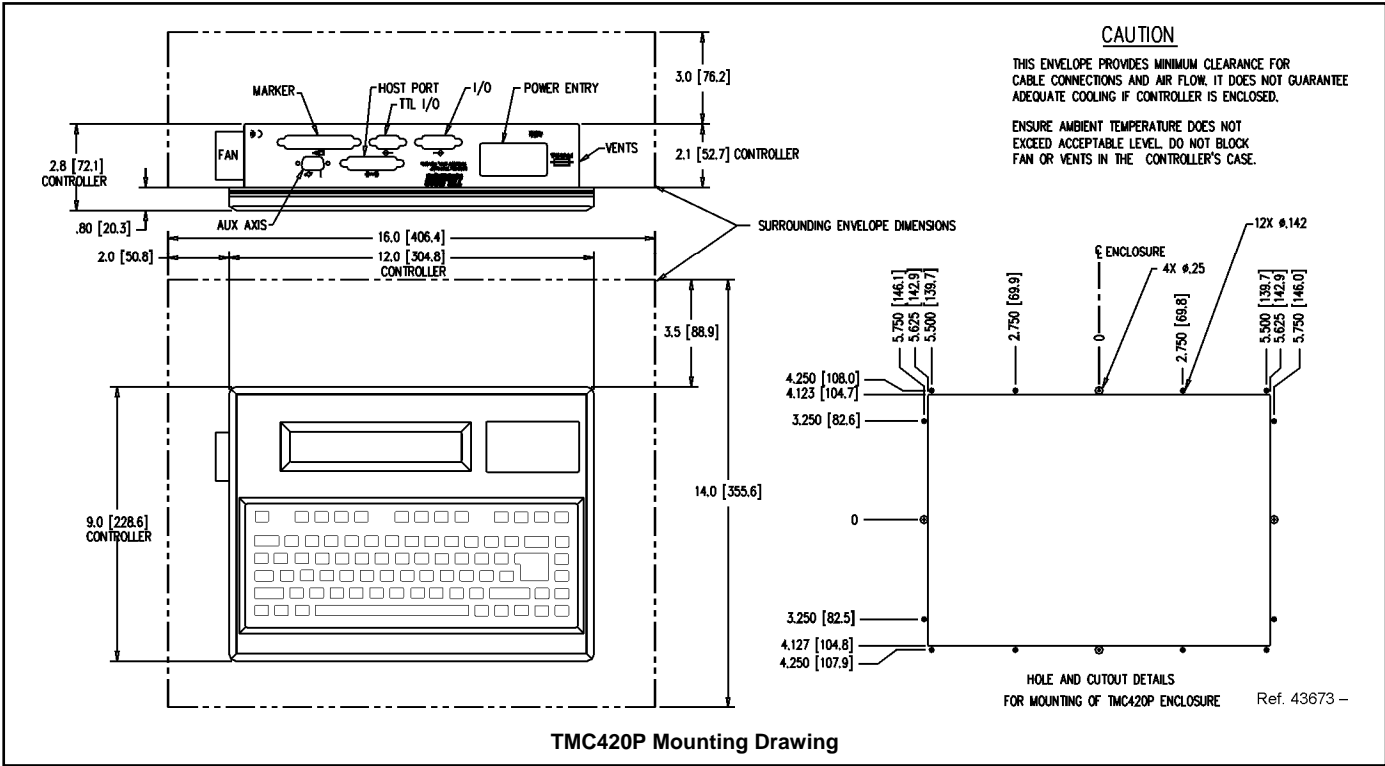

I/O Control Signals. The TMC420 is configured for DC I/O only. The TTL I/O Port may be used to connect a remote pushbutton control for Start Print and Abort commands. The I/O Port may be used to connect a PLC or other DC I/O source. The I/O Port allows remote control of pattern selection, printing, aborting, placing the marker online, and monitoring of the Ready and Done output signals. Cable connectors and connector pins are supplied with the controller for constructing appropriate interface cables.

- START PRINT** Input signal, begins print cycle
- SEL_0, 1, 2, 3 *** Input signals, remote pattern selection (15* max.)
- SEL_3 *** Input signal, marker online
- ABORT** Input signal, aborts print cycle
- INPUT COMM** For all inputs (+ or - supply)
- READY** Output signal, ready for message or start print
- DONE** Output signal, print cycle complete

OUTPUT COMM For all outputs (+ or - supply)
 * System software allows SEL_3 signal to be configured for remotely selecting patterns or for remotely placing the marker online. If used for marker online, pattern selection is reduced to 7 patterns (max).

Serial Communications. The Host Port may be used for either RS-232 or RS-485 communication. The RS-232 interface is most often used with remote devices such as bar code readers or host computers. The RS-485 interface is normally used for long transmission distances or multi-drop networks of up to 31 TMC420 controllers. The serial port may be configured to communicate using either the Telesis Programmable Protocol or Telesis Extended Protocol. The following describes the serial data character format on all transmissions to and from the TMC420 controller.

- Asynchronous
- 1200, 2400, 4800, 9600, or 19200 baud-host
- One Start Bit
- One or Two Stop Bit(s)
- Seven or Eight Data Bits
- None, Even or Odd Parity

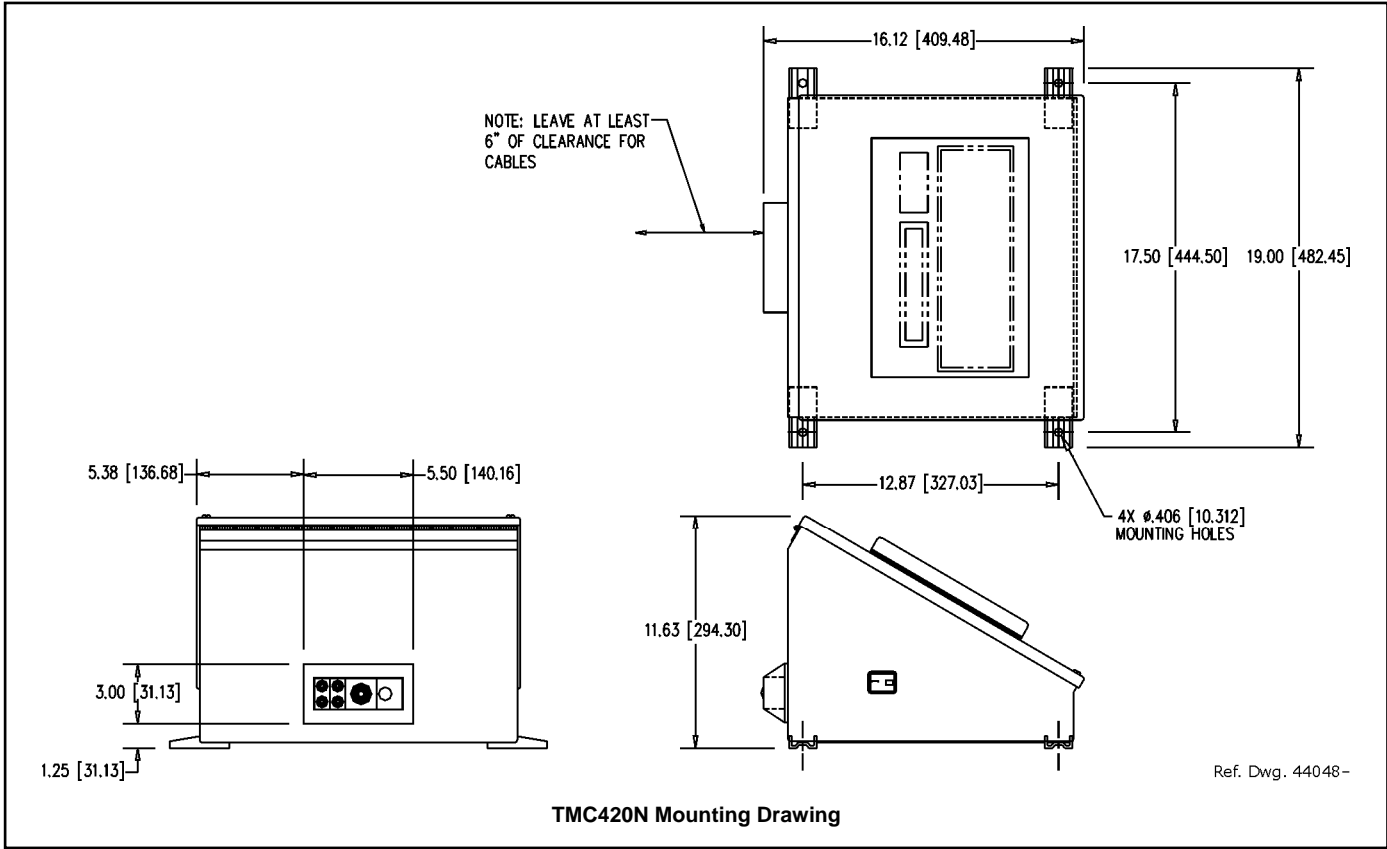

Programmable Protocol is used where very simple one-way communications are required (such as with bar code scanners). Programmable Protocol provides no error checking or acknowledgment of the transmitted data. Note that XON/XOFF Protocol applies even when Programmable Protocol is selected.

Starting Character specifies where the software begins to count character positions. This number must be entered in ASCII decimal format such as 2 for STX.

Terminating Character identifies the end of transmitted string (usually ASCII carriage return character, decimal 13).

Character Position counted from the starting character ignoring all characters preceding it.

Character Length accepts variable length messages (if set to 0) or messages of a pre-specified, fixed number of characters.

Ignore Character identifies the character to ignore when sent from the host (usually ASCII line feed character, decimal 10).

Message Type allows message-type recognition which defines how the marking system will use data it receives from the host..

- P** loads a specific pattern identified by data extracted from host
- V** updates first variable text field with data extracted from host
- 1** overwrites first text field with data extracted from the host
- Q** updates text in first query buffer with data extracted from host
- 0** indicates that host will provide message type, field number (if applicable), and data; delegates message type selection to the host on message-by-message basis. The host message must use the format **Tnn<string>** where:
 - T** = P, V, 1, or Q to indicate the message type.
 - nn** = two-digit number to indicate field number or query text buffer where data will be placed. Note that a number is not used with Message Type P.
- <string>** = pattern name (Message Type P) or field data (Message Types V, 1, or Q), as applicable.

Extended Protocol includes error checking and transmission acknowledgment. It should be used in applications where serial communication is a vital part of the marking operation. Extended Protocol must be used in multi-drop applications. All communications are carried out in a master-slave relationship with the host being the master. Only the master has the ability to initiate communications. If the host does not receive a response within three seconds, it should re-transmit its original message. If no response is received after three tries, it should declare the link to be down.

The following describes the message format as sent from the master to the TMC420 controller.

SOH TYPE [##] STX [DATA TEXT] ETX BCC CR

SOH ASCII Start of Header character (001H). The controller ignores all characters received prior to the SOH.

TYPE A single, printable ASCII character that defines the meaning (type) and content of the message downloaded from the host, where:

- 1** overwrites the specified field of currently loaded pattern, using the format **1nn<string>** where nn is the field number.
- V** updates specified variable text field of currently loaded pattern, using the format **Vnn<string>** where nn is the field number.
- Q** updates specified query buffer with data received from host, using the format **Qnn<string>** where nn is the buffer number.
- P** specifies pattern name to be loaded for printing
- O** resets marker and places it online
- G** initiates a print cycle to mark the currently loaded pattern
- I** requests the marker output status; returns a single-digit hexadecimal value to report state of READY and DONE:

Returned Value	DONE	READY
0	off	off
1	off	ON
2	ON	off
3	ON	ON

- S** requests the marker error status; returns a value that represents a particular type of error:

Returned Value	Type of Error
0x0000	no error
0x0001	ONLINE_ERROR
0x0002	PATTERN_LOAD_ERROR
0x0004	DISALLOWED_NO_PATTERN
0x0008	DISALLOWED_OFFLINE
0x0010	PATTERN_FIELD_ERROR
0x0020	MARKER_ABORTED_ERROR
0x0040	FILE_TRANSFER_ERROR
0x0080	PIX_OUT_OF_RANGE_ERROR
0x0100	RAM_ERROR
0x0200	SN_RANGE_ERROR
0x8000	undefined error

[##] Two optional ASCII decimal digits that specify the Station ID number for use in multi-drop network applications. The ID may range from 00-31. Note that “00” is reserved for applications where only one controller is used. In such applications, this field may be eliminated and “00” will be assumed.

STX ASCII Start of Text Character (002H).

[DATA TEXT] Optional field that may be required for certain message types.

ETX ASCII end of text character (003H).

BCC Optional Block Check Code that is generated and sent to improve link reliability by providing fault detection. The BCC is calculated by taking an eight bit addition of the TYPE and DATA TEXT characters and transmitting them as a three digit ASCII decimal number in the range from 000 to 255. If the sum is greater than 255, the most significant bit overflows and is discarded.

CR ASCII Carriage Return Character (00DH).

TRADEMARKS

Telesis and **PINSTAMP** are registered trademarks of Telesis Technologies, Inc. in the United States and/or other countries.