

Description of Equipment

The Theta-axis (rotational axis) works in conjunction with the Telesis Rotary Drive Fixture. The fixture is an electromechanical device that holds and rotates parts for marking. It is designed to mark cylindrical parts or to mark multiple flats on square or hexagonal parts.

Two versions of the rotary drive fixture are available. The RD3 uses a 3-in. diameter chuck. The RD5 uses a 5-in. diameter chuck. A typical Theta-axis installation uses the following components.

- Rotary Drive Fixture** RD3 or RD5 (described above). Refer to mounting drawing for more details.
- Dual Driver** Device that processes I/O signals from the marking system controller to drive the auxiliary axis (or axes)
- Interface Cable Ass'y** Cable connecting the Dual Driver to the marking system controller
- Drive Cable Ass'y** Cable connecting the Dual Driver to the auxiliary axis drive unit(s)
- Tool Post Base** Mounting fixture on which the rotary drive fixture is installed
- Adapter Plate** Fixture that mounts between the tool post base and rotary drive fixture to permit alignment of Theta-axis within the marking window.
- Attaching Hardware** Nuts, bolts, washers, etc. to mount the Theta-axis components.

System Availability

The following Telesis Marking Systems may be configured with an optional Theta-axis using the RD3 and RD5 rotary drive fixtures.

Marking System	RD3 3" Chuck	RD5 5" Chuck
BenchMark320	✓	✓
TMP1700 / TMC090	✓	✓
TMP1700 / TMC420	✓	✓
TMP3200 / TMC090	✓	✓
TMP3200 / TMC420	✓	✓
TMP6100 / TMC090	✓	✓

Mounting Bases

Several Telesis-supplied tool post bases may be used to mount the RD3 and RD5 rotary drive fixtures. Refer to *Marking Window Alignment* for more information on use of these tool post bases with the rotary drive fixtures.

Tool Post Base	RD3 3" Chuck	RD5 5" Chuck
BenchMark320 Base (41212)	✓	✓
TMP1700 Base (28952)	✓	
Standard Base (15002) *	✓	✓

* Standard base used with TMP3200, TMP6100.
Standard base required for TMP1700 when 5" chuck (RD5) is used.

THETA-AXIS ROTARY DRIVE DATASHEET

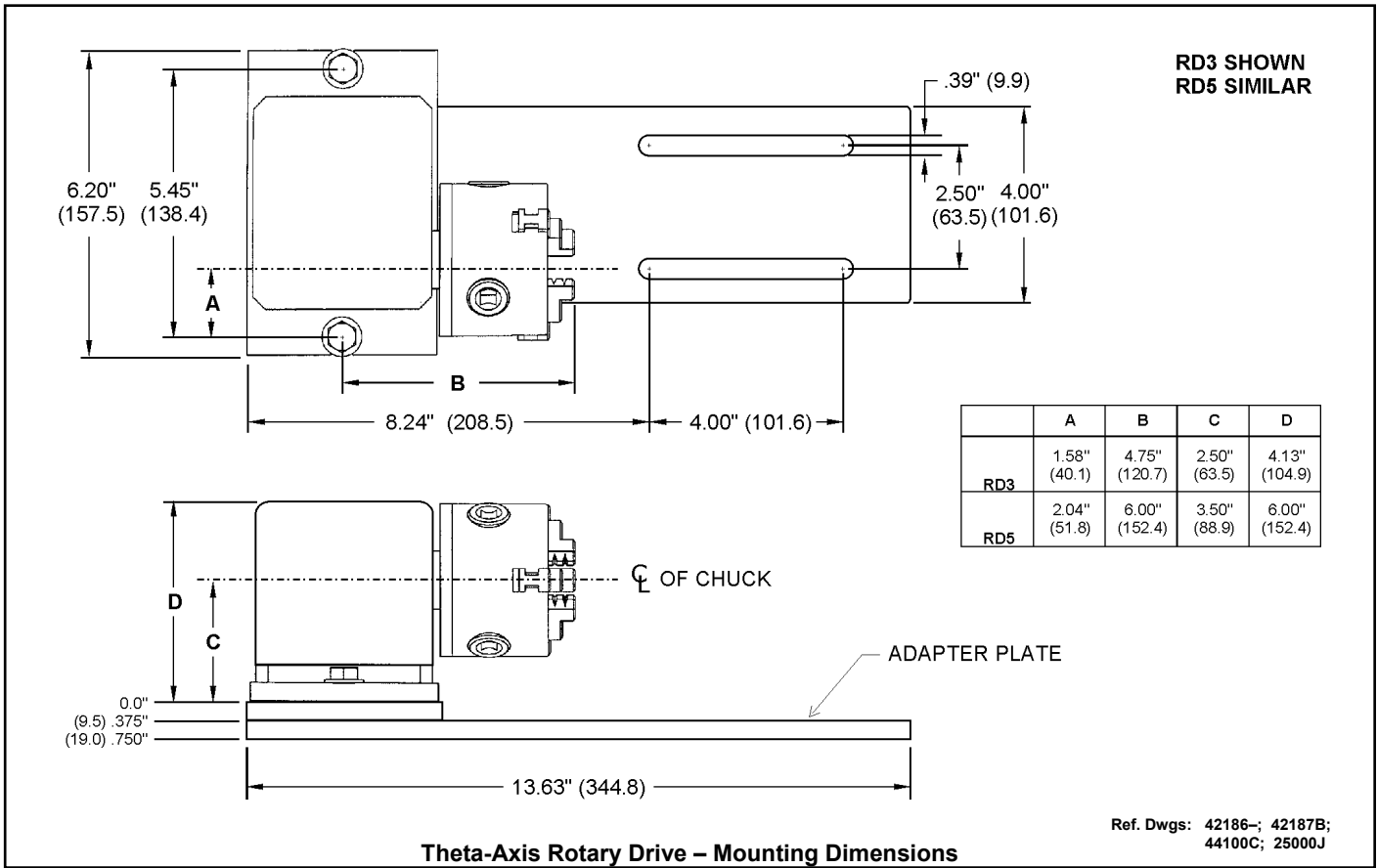

Theta-Axis Rotary Drive – Mounting Dimensions

Part Diameters

The RD3 and the RD5 rotary drives both provide chucks with adjustable jaws to accommodate parts of various diameters. The following illustration shows a typical fixture in two chuck configurations. The following tables list the various part diameters that can be held by the fixtures in each configuration.

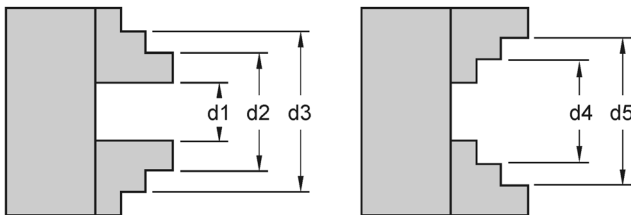

RD3 Part Diameters

d1 (range)	D2 (range)	d3 (max)	d4 (max)	D5 (max)
.08 - .87 "	.98 - 1.77 "	2.76 "	.87 "	2.48 "
2 - 22 mm	25 - 45 mm	70 mm	22 mm	63 mm

RD5 Part Diameters

d1 (range)	d2 (range)	d3 (max)	d4 (max)	D5 (max)
.118 - 1.97 "	1.34 - 2.91 "	4.53 "	3.27 "	4.92 "
3 - 50 mm	34 - 74 mm	115 mm	83 mm	125 mm

Moments of Inertia

The moment of inertia is a measure of the mass of an object and the concentration of that mass relative to the center of its rotation. When using the Theta-axis, the moment of inertia for the part being marked should not exceed the following limits.

RD3 max moment of inertia: 52 lb-in² (15.2 x 10⁶ g-mm²)

Examples:

- Steel cylinder 23" long x 3" dia. weighing 46 lb.
- Steel cylinder 584 mm long x 76 mm dia. weighing 21 kg.

RD5 max moment of inertia: 294 lb-in² (86.1 x 10⁶ g-mm²)

Examples:

- Steel cylinder 16.9" long x 5" dia. weighing 95 lb.
- Steel cylinder 429 mm long x 127 mm dia. weighing 43 kg.

Marking Window Alignment

When mounting the rotary drive fixture, ensure the part to be marked will be properly positioned within the available marking window. Note that the drive fixture adapter plate is slotted. This allows maximum adjustment of the rotary drive fixture (left, right, forward, and aft) relative to the tool post base and the subsequent marking window location.

Theta Marking Modes

There are several parameters in the marking system software that define how the rotary drive fixture will perform when it prints using the Theta-axis. Some of the settings are defined in pattern-level parameters; others are defined within specific text field definitions.

PATTERN PRINT MODES

The Theta mode parameter defines how the system will rotate the Theta-axis when the pattern is printed. Because this is a pattern parameter, the selected method will apply to all objects printed by the pattern. However, you can override the Theta mode selection when you print text fields (see *Text Field Print Modes*, below).

Off disables the Theta-axis features for this pattern. However, the system will still rotate the fixture to its Theta-axis Home position when the machine is placed online.

Perpendicular Mode (available only with RD5 rotary drive) This is typically used to mark cylindrical parts (e.g., pipe or tubing). The system substitutes normal movement along the Y-axis with rotational movement about the Theta-axis. In Perpendicular Mode, the system rotates the Theta-axis while the marker is printing fields (and may even rotate between printing pixels). This may result in slower marking times, but provides a high quality mark since the impact pin is always perpendicular to the marking surface.

Index Mode is typically used to mark flat surfaces on square or hexagonal parts (e.g., sides of bolt heads). The system rotates the Theta-axis a specific number of degrees to index the side of the part, marks the part, then rotates (indexes) to the next side, and so on. In Index Mode, the system does not rotate the Theta-axis while the marker is printing a field. It may, however, rotate between printing fields.

TEXT FIELD PRINT MODES

Each text field contains a Print Mode parameter that defines how the system will rotate the Theta-axis when the field is printed.

Standard will use the mode defined for the pattern. See above.

Index (Character Index) will override the pattern print mode and use character index printing for this text field. The system will print one character, rotate the Theta-axis, print the next character, rotate, and so on. Character indexing is normally faster because it results in less “rotational interruption” to the printing cycle. Since this parameter is a field parameter, you can enable it for some or all of your text fields within the same pattern on a field-by-field basis.

- ▶ When Character Index is selected, the text field must be printed perpendicular to the rotational axis (i.e., at either 90° or 270°).

Software Configuration

Two software parameters define the hardware configuration of the rotary drive fixture: part diameter and mounting angle.

PART DIAMETER

The part diameter defines the size of the part being marked. Based on the diameter, the system calculates the rotational distances necessary to mark the pattern around the circumference of the part.

MOUNTING ANGLE

The mounting angle is determined by the installation of the rotary drive fixture. Typically, the fixture is mounted such that the rotational axis is parallel to the X-axis of the marking window (0° mounting). If necessary, the fixture may be mounted at other angles to provide the best positioning of the part within the marking window. If so mounted, this parameter can be configured to define the actual mounting angle.