

### System Overview

The Telesis® EV10 is an advanced, fiber-coupled diode-pumped solid state (DPSS) laser marking system. The laser beam and Q-switched pulse characteristics are optimized for applications that require high beam quality and stability. In addition, the EV10 offers extra power and speed for precision marking and material processing applications. Its short pulse width and extremely small spot size provide high resolution marking with minimal heat impact to surrounding areas. These characteristics make it an ideal choice for general-purpose laser marking, scribing, trimming, and other material processing applications.

The EV10 features a Q-switched Nd:YVO<sub>4</sub> diode-pumped laser with a remote fiber-coupled diode pump source. With average diode life of greater than 20,000 working hours the EV10 offers the user “best-in class” reliability.

The robust mechanical and optical design allows the Telesis EV10 to operate in an industrial environment where shock, vibration, and dust are a concern.

The laser marking system offers these advantages:

- Reliable, long, maintenance-free performance
- Compact size and modular construction
- Remote, fiber-coupled pump diode
- Exceptional beam quality and stable output power
- Active (thermo-electrical) temperature control of the laser crystal and pump diode
- Active AO Q-switching
- Air cooling
- Visible red diode for dry run / positioning
- Large digital display for marker status, settings, and error condition monitoring
- Standard 115/230VAC operation
- DoD-compliant Unique Identification (UID) marking

### System Configuration

The EV10 is available in two configurations: one for marking only stationary objects, another for marking objects while they are moving (i.e., mark-on-the-fly operation). The basic laser marking system consists of the following components:

- **Laser Controller** – contains pump diode, RF driver, and other electrical components
- **Fiber Optic Cable Assembly**
- **Laser Marking Head** – contains sealed resonator, beam expander, galvanometer assembly, visible red aiming diode
- **Software** – Merlin II LS Laser Marking Software
- **System Computer** – supplied by Telesis or by customer

The modular design allows for major components to be easily replaced and returned to Telesis if required.

### Laser System Options

- Desktop computer or Notebook computer with powered cardbus-to-PCI expansion enclosure
- Externally-mounted focus-finder diode
- Mark-on-the-fly (MOTF) kit to interface with customer-supplied encoder for marking objects in linear or circular motion.
- Tool post w/ manual hand crank for z-axis adjustment
- Pushbutton station (start/abort)
- I/O Options:  
TTL via PCI-DIO24 Card (Kit #53920)  
Opto-isolated via Merlin DCIO Module (Kit #53928)  
Two-axis Controller (for auxiliary axes; additional I/O)
- Programmable X-, Y, or Z-axis (requires two-axis controller)
- Rotary drive fixture (requires two-axis controller)
- Vacuum System
- Workstation / Work area enclosures

# EV10 Laser Marking System

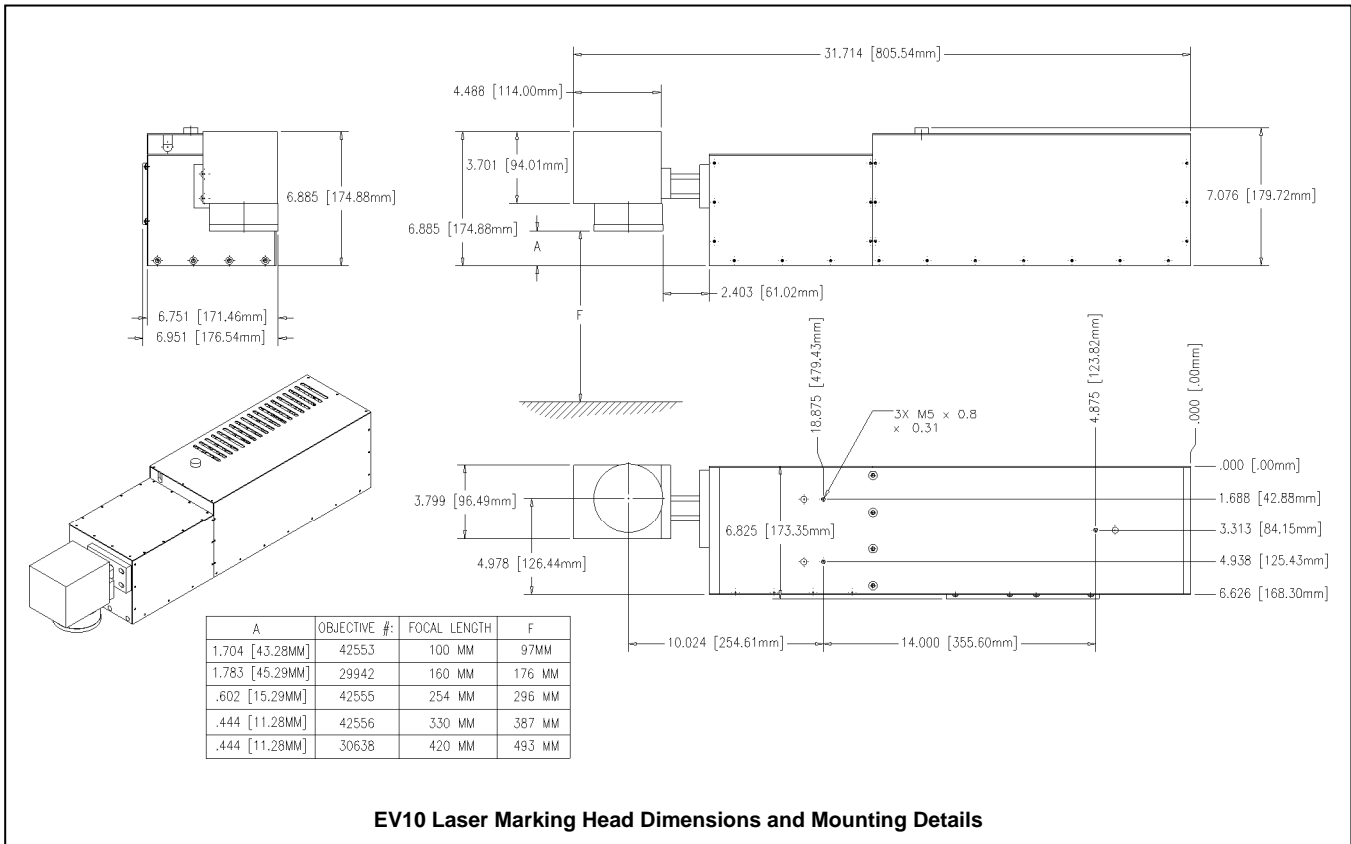

EV10 Laser Marking Head Dimensions and Mounting Details

## System Setup

Complete installation procedures are provided in the *EV10 Installation/Maintenance Manual*. The following procedures are listed for reference only to provide a general overview of the installation process.

- Equipment should remain powered down and in OFF position until mounting is complete.
- Place computer, monitor, keyboard, and laser controller in desired location. Locate controller as close as practical to laser marking head – typically within 1.5m (5.0 ft.). Ensure sufficient clearance on sides of laser controller (approx. 65 mm or 2.5 in.) to allow for air circulation.
- Place the laser marking head on selected mounting.
  - Do not bend or kink fiber optic cable.** The fiber optic cable will tolerate approximately 300 mm (12 in.) diameter bend without damage.
  - Allow a minimum distance of 150 mm (6 in.) at rear of the laser marking head.** This will provide sufficient room for a proper bend radius of fiber optic cable.
  - Do not block or obstruct exhaust fans.** Note location of exhaust fans on right side of the laser marking head. These fans must have adequate clearance to ensure proper cooling.
  - Ensure sufficient clearance on all sides of laser marking head (approx. 65 mm or 2.5 in.) to allow for air circulation.
- Mount laser marking head using three factory-tapped M5-0.8 mounting holes provided.
  - Locate the three pre-drilled M5-0.8 mounting holes. Refer to the *Mounting and Dimension Details* drawing more information.
  - Mounting bolts must not extend into laser marking head more than 7.8 mm (.31 in.)** to avoid interference with internal components.
  - The leading edge of customer-supplied mounting fixture should extend no greater than 50 mm (2 in.) from forward edge of laser marking head rail assembly to allow clearance for beam output lens.
  - As viewed from front of the laser marking head in upright position, center of output beam is 254.61 mm (10.024 in.) forward of the front set of mounting holes in the laser rail assembly.
- Secure the laser marking head to mounting fixture using three M5-0.80 bolts and lock washers. Torque to 47 in-lb (5.31 N-m). **Do not over tighten bolts.**
- Ensure laser controller power switch (front panel) is OFF.
- Select proper fuse arrangement, then connect power cable.
- Connect fiber-optic cable to laser marking head. Connect remaining cables, as applicable.
- Refer to *EV10 Operation Supplement* for proper startup procedure. Refer to laser marking system *Operation Manual* for complete information on using system software.

## System Specifications

Compliance.....	CDRH
Laser Type.....	fiber-coupled, diode-pumped, Q-switched, Nd:YVO <sub>4</sub>
Wavelength.....	1064 nanometers (nm)
Average Power .....	10 watts at 1064 nm
Expected Diode Lifetime.....	greater than 20,000 hours
Long Term Output Power Drift ..	less than ± 2%
Max. Power Consumption .....	less than 500 watts
Input Power .....	95 to 250 VAC, 6 amps, 50/60 Hz single phase
Supply Voltage Fluctuation .....	± 10%, max.; clean ground line
Oper. Temperature.....	18° to 30°C (65° to 86°F)
Recommended Temp. ....	20° to 25°C (68° to 77°F)
Oper. Relative Humidity.....	10% to 85% non-condensing

## Laser Marking Head

The E-series lasers are designed for easy maintenance. Heat exhaust fans are located on the right side of the unit.

The laser marking head encloses the sealed laser resonator, the beam expander, the red light dry run/positioning laser and the galvanometer assembly.

## Laser Marking Head Specifications

Dimensions (L x W x H) .....	805.54 x 176.54 x 179.72 mm (31.714 x 6.951 x 7.076 in.)
Surrounding Envelope .....	875 x 245 x 245 mm (34.5 x 9.75 x 10 in.)
Mounting Weight.....	approx. 20 Kg (45 lbs.)
Mounting Holes .....	three factory-tapped M5-0.80
Positioning.....	visible red diode beam (650 nm)
Field Resolution.....	16 bit (65535 data points)
Galvanometer Repeatability ..	less than 22 micro radian
Marking Field Size .....	lens-dependent, see chart
Fiber-Optic Cable Length.....	1.75 m (5.73 ft.)
Cooling .....	air cooled, active thermo-electric

## Sealed Laser Resonator

The laser resonator is assembled and sealed in the clean room environment to prevent contamination. The laser marking head contains an electro-mechanical safety shutter. Under power, the safety shutter allows 1064nm laser beam to pass through the galvanometer steering mirrors. If the shutter is closed during normal operation (or power is removed from the system via a power off/stop condition) it will block the 1064nm laser beam.

## Visible Red Aiming Diode

The laser marking head produces a visible red diode that may be viewed on the work surface without the need for protective safety goggles. This provides a safe and convenient aid for laser setup and part programming. Since the red beam is located *after* the shutter, the aiming diode may be used with the shutter opened or closed. Additionally, the visible red beam may be used with the lasing beam during the marking cycle. **Note that protective eyewear must always be worn when the laser is in operation.**

## Flat Field Lens, Final Objective Lens, (F-Theta Lens)

The final object lens is key to the marking performance of the system. This is the final coated optical lens that the beam will pass through before it strikes the marking target. This lens is called a flat field lens because when the beam is focused, the focus lies in a plane perpendicular to the optical axis of the lens. To protect the final objective lens from dust and debris, a clear protective cover is inserted between the work area and the lens.

The following chart outlines the available lenses, the resulting image field provided by the lens, and the working clearance (in millimeters and inches).

Lens	Image Field		Working Clearance	
	(mm)	(in.)	(mm)	(in.)
100 mm	65 x 65	2.56 x 2.56	97	3.82
160 mm	110 x 110	4.33 x 4.33	176	6.93
254 mm	175 x 175	6.89 x 6.89	296	11.65
330 mm	230 x 230	9.06 x 9.06	387	15.24
420 mm	290 x 290	11.42 x 11.42	493	19.41

## Laser Controller

The pump diode is enclosed in the laser controller, while the laser resonator with the crystal is located in the laser marking head. The pump beam from the diode (approx. 808 nm) is delivered through a fiber optic cable directly into the laser resonator. This compact laser controller can be fitted to any standard-rack mount or it can be placed directly upon a desktop.

The laser controller also contains the active thermo-electrical cooling system for the pump diode, the RF driver, galvanometer power supply, driver control circuits, appropriate fusing, and a 115/230VAC IEC320 connector, and a front panel control module.

Engineered for the greatest reliability and for ease of maintenance, the pump diode within the laser controller is an easily replaceable sealed module with expected lifetime of greater than 20,000 operating hours.

## Operator Control Panel

The front panel includes the system key switch, laser off push button, manual safety shutter control, function indicators, and LCD display. The display allows monitoring of the diode current, the crystal and diode temperatures, system status, and error conditions.

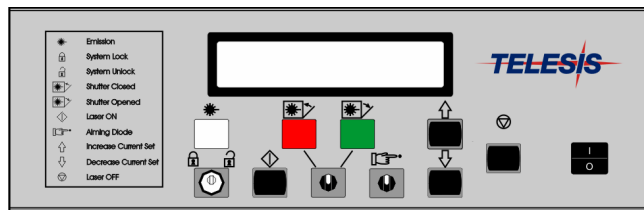

XP1 Laser Controller

## Laser Controller Specifications

Dimensions (W x H x D) .....420 x 140 x 500 mm  
(16.5 x 5.5 x 19.5 in.)

Surrounding Envelope .....500 x 140 x 560 mm  
(19.5 x 5.5 x 22.0 in.)

Weight .....approx. 10 Kg (22 lbs.)

Cooling .....air cooled, active thermo-electric

## Fiber Optic Cable Assembly

The fiber optic cable is permanently attached to the pump diode within the laser controller and cannot be removed. The standard optical fiber for the EV10 is 2 meters (6.56 feet) long.

## System PC

The laser system requires an IBM-compatible computer for running the Merlin®II LS Laser Marking Software. The PC may be a desktop or a notebook computer and may be supplied by Telesis or by the customer. If the PC is supplied by Telesis, warranty for the computer, computer keyboard, monitor, and peripherals default to the original equipment manufacturer.

Galvo control cards are included, along with interconnect cabling. The laser software is installed and the entire unit is tested as a laser marking system.

The minimum computer requirements are as follows:

- Windows® 2000, Windows® XP or Windows® Vista™ Business
- Telesis Merlin II LS Laser Marking Software
- Pentium® III with recommended RAM as per operating system
- Multi-gigabyte, HDD
- CD-ROM and 3.5 in. External Disk Drives
- SVGA Color Monitor, Mouse, and Keyboard
- Laser/Galvo Controller Board
- Video Card
- One available RS-232 Serial Port
- Two available USB Ports
- Two (minimum) full-height PCI Slots \*

**Note:** If a notebook computer is used, expansion must be used to provide the PCI slots.

## System Software

The powerful Telesis Merlin II LS Laser Marking Software is a Windows® based software package that comes standard with the laser marking system. It is a graphical user interface that makes marking pattern design quick and easy. The WYSIWYG (what-you-see-is-what-you-get) interface provides a to-scale image of the pattern as it is created. Just “click and drag” for immediate adjustment to field size, location, or orientation.

The Merlin II LS includes tools to create and edit text (at any angle), arc text, rectangles, circles, ellipses, and lines. Multiple fields may be grouped and saved as a block to form a logo. Existing DXF files can also be imported for marking. Non-printable fields can be created to clearly display a graphical representation of the part being marked.

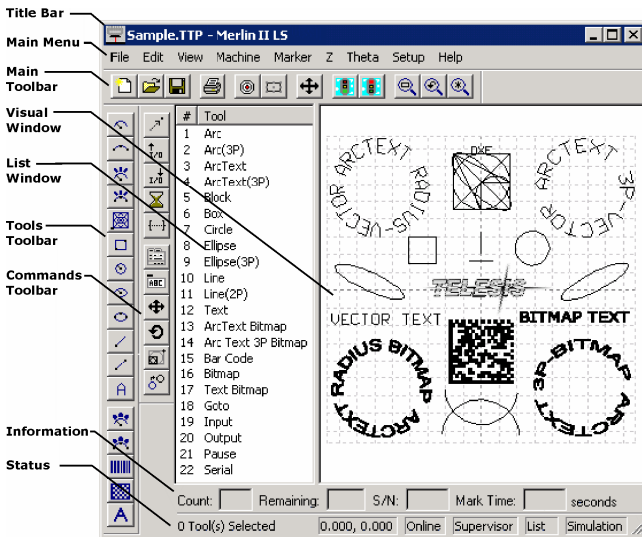

Overview of Merlin-II LS User Interface

## Merlin II LS Laser Marking Software Specifications

Operating System .....	Windows® 2000, Windows® XP, or Windows® Vista™ Business with Desktop PC or Notebook PC
Font Generation .....	True Type Fonts
Barcodes and Matrix .....	2D Data Matrix, PDF417, BC 39, Interleaved 2 of 5, UPCA/UPCE BC 128, Maxi Code, Code 93, QR Code and others
Graphic Formats .....	Raster and Vector: BMP, GIF, JPG, WMF, EMF, DXF, CUR, ICO
Serialization .....	Automatic and Manual Input Host Interface Capable
Linear Marking .....	Scalable with Letter Spacing Control
Arc Text Marking .....	Scalable and Adjustable
Drawing Tools .....	Line, Rectangle, Circle, Ellipse

## Remote Communications

The communication capability of the marking system software allows you to control the laser from remote I/O devices. Remote communications can be performed by connecting to a Host computer, an optional I/O card, or an optional two-axis Auxiliary Controller.

The rear panel of the controller also provides a connector to monitor output signals that report the status of the shutter, laser emission, and fault conditions.

**Host Communications.** Remote communications may be executed from a host computer using RS-232 or Ethernet (TCP/IP) connections to the system computer (i.e., the PC running the Telesis laser marking software). The software provides parameters to define the data transmitted to and from the host. For more information on using and configuring these parameters, refer to the *Operation Manual* supplied with the laser marking software.

**I/O Card.** Telesis offers an optional I/O card that provides six input signals (Start Print, Abort, and four programmable inputs) and six output signals (Ready, Done, Paused, and three programmable outputs). The I/O card is available in the following kits. For more information on using the optional I/O card, refer to the *Optional I/O Card Installation Supplement* supplied in each of these kits.

**Kit #53920** This kit is available for all Telesis laser systems. It includes the I/O Card, SIPs resistor packs (pre-installed), the software driver CD, and installation documentation. This kit does not provide opto-isolated signals. If this kit is used, it is the responsibility of the installer/integrator to provide opto-isolation between remote I/O devices and the I/O card. Refer to the OEM *User's Guide* for signal limitations.

**Note:** Telesis does not endorse direct connection of I/O signals to the I/O card. Direct connections to high current/high voltage devices will damage the card.

**Kit #53928** This kit is available for all laser systems that use the Merlin-II LS Laser Marking Software. It includes Kit #53920 (above), plus the Telesis I/O Interface Module and two cable assemblies. This kit provides opto-isolated signals between remote I/O devices and the I/O card through the Telesis I/O Interface Module. Additional opto-isolator board assemblies or opto-isolated I/O rack assemblies are not required when the interface module is used.

**Two-axis Controller.** Telesis offers an optional two-axis controller for all laser systems that use the Merlin-II LS Laser Marking Software. The auxiliary controller provides an interface for connecting six input and six output signals to and from the laser marking system, and for connecting the optional auxiliary axes: vertical (Z) axis, rotational (Theta) axis, and linear (L1 and L2) axes.

Environmental considerations must be taken into account when installing the auxiliary controller concerning contaminants and EMI susceptibility. For details, refer to the *Installation/Maintenance Manual* supplied with the controller.

## Communications Protocol

Two types of host interface are supported (RS-232 or TCP/IP) and two communication protocols are provided through the Merlin-II LS marking system software (Programmable and Extended).

**Programmable Protocol.** Programmable protocol provides one-way (receive only) communication with no error checking or acknowledgment of the transmitted data. You may use Programmable protocol to extract a continuous portion of a message string to print. This can be used with a host computer or a bar code scanner. Note that XON/XOFF Protocol applies even when Programmable Protocol is selected.

The Programmable Protocol Message Type identifies the type of message sent from the host. It determines how the marker uses the data it extracts from the host message string when Programmable Protocol is used.

- 49** Message type 49 ("I") overwrites the content of the first text-based field in the pattern with the data extracted from the host message. Note that if the field contains message flags, they will be overwritten, not updated.
- 65** Message type 65 ("A") updates the Offset Angle parameter with the data extracted from the host message. Syntax for the transmitted string is  $\pm n$  where  $\pm$  is a positive or negative sign and  $n$  is an integer that represents the offset angle for the marking window.
- 72** Message type 72 ("H") updates the Offset X/Y parameters with the data extracted from the host message. Syntax for the transmitted string is  $\pm X.X, \pm Y.Y$  where  $\pm$  is a positive or negative sign,  $X.X$  represents the X-axis offset distance, and  $Y.Y$  represents the Y-axis offset distance.
- 80** Message type 80 ("P") indicates the data extracted from the host message is the name of the pattern to be loaded.
- 81** Message type 81 ("Q") updates the text in the first query text buffer (buffer 0) with the data extracted from the host message.
- 86** Message type 86 ("V") updates the text in the first variable text field in the pattern with the data extracted from the host message.
- 118** Message type 118 ("v") updates the first text field encountered in the pattern that contains a variable text flag that matches the specified string length.

If the host is providing the Message Type within the transmitted text string, enter "0" in the Message Type parameter text box displayed on the Programmable tab of the Host/Setup window.

- 0** Message type 0 (zero) indicates that the host will provide the message type, field number (if applicable), and data (if applicable). This option allows more flexibility by delegating the message type selection to the host on a message-by-message basis. It also allows you to direct data to specific fields and/or query text buffers.

The host can use Message Type 0 to provide data to the marking system. The marking system will insert data transmitted with the message into the appropriate location.

## Communications Protocol (continued)

**Extended Protocol.** Extended protocol provides two-way communication with error checking. It is designed to provide secure communications with an intelligent host device using pre-defined message formats and response formats. It also provides error checking using a block check code to detect faults in the transmitted messages and to verify the data is properly received.

The Extended Protocol Message Type determines how the marker uses the data it extracts from the host message string or from the marking system software, as applicable.

- I** Message Type "I" can provide data to a text string in the pattern or poll the pattern for data.
- A** Message Type "A" can provide data to the system Offset Angle parameter for the marking window or poll the system for data.
- E** Message Type "E" allows the host to take the machine offline. It also provides the option of displaying an error message box with the provided data string.
- V** Message Type "V" can provide data to a variable text string in the pattern or poll the pattern for data.
- P** Message Type "P" can load a pattern or poll the system for the current pattern name.
- O** Message Type "O" places the marker online. This allows a host computer to reset. For example, this may be used to recover from a power outage when the marker is unattended.
- G** Message Type "G" initiates a print cycle.
- Q** Message Type "Q" can provide data to the system query text buffer or poll the system for data.
- H** Message Type "H" can provide data to the system X/Y Offset parameters or poll the system for data.
- S** Message Type "S" is used to poll the system for the machine status. The machine status is returned to the host in an eight-character hexadecimal mask.
- I** Message Type "I" is used to poll the system for the I/O status.

## TRADEMARKS

**Telesis** and **Merlin** are registered trademarks of Telesis Technologies, Inc. in the United States and/or other countries.

**Pentium** is a registered trademark of Intel Corporation in the United States and other countries.

**Vista** is a trademark of Microsoft Corporation in the United States and other countries.

**Windows** is a registered trademark of Microsoft Corporation in the United States and other countries